



Electromechanical Tripod Turnstile

TTR-04CW

ASSEMBLY AND OPERATION MANUAL



CE EAC



Electromechanical Tripod Turnstile

TTR-04CW

Assembly and Operation Manual

CONTENTS

1	APPLICATION.....	3
2	OPERATION CONDITIONS.....	3
3	TECHNICAL SPECIFICATIONS	4
4	DELIVERY SET.....	5
4.1	Standard delivery set.....	5
4.2	Optional equipment supplied on request	5
5	PRODUCT DESCRIPTION	7
5.1	Main features.....	7
5.2	Design	7
5.3	Control over the turnstile	11
5.4	Input and output control signals and their parameters.....	12
5.5	Control modes	13
5.6	Operation with RC panel	14
5.7	Operation with WRC.....	15
5.8	Operation with ACS controller	15
5.9	Optional external devices connected to the turnstile	15
5.10	Key override control.....	17
5.11	Operation contingencies and response	17
6	MARKING AND PACKAGING.....	18
7	SAFETY REQUIREMENTS.....	18
7.1	Installation safety requirements.....	18
7.2	Operation safety requirements	18
8	INSTALLATION INSTRUCTIONS	19
8.1	Installation details	19
8.2	Installation tools.....	19
8.3	Cable length	20
8.4	Installation procedure	20
9	OPERATION INSTRUCTIONS	22
9.1	Power-up.....	22
9.2	Turnstile operating modes in pulse control mode	22
9.3	Turnstile operating modes in potential control mode	24
9.4	Actions in emergency	25
9.5	Troubleshooting.....	25
10	MAINTENANCE	26
11	TRANSPORTATION AND STORAGE	27
	Appendix A Control signal algorithm at pulse control mode.....	28
	Appendix B Control signal algorithm at potential control mode.....	29

Dear customers!

*We thank You for choosing the turnstile manufactured by PERCo.
You have purchased a high quality product, which will be long lasting
in operation provided that installation and operation rules are observed.*

The assembly and operation manual (hereinafter - the Manual) for the **TTR-04CW** electromechanical tripod turnstile (hereinafter - the turnstile) contains data that is necessary for the most full use of operating advantages of the turnstile as well as chapters on packaging, installation and maintenance.

Only qualified personnel, following the instructions of this Manual, must carry out installation and maintenance.

Abbreviations:

- ACS – access control system;
- RC panel – remote control panel;
- WRC – wireless remote control.

1 APPLICATION

The turnstile is designed for managing pedestrian flows at entrance points of industrial facilities, banks, administrative buildings, retail outlets, railway terminals, airports, etc.

To ensure fast and convenient passage it is recommended to install one turnstile per 500 people working the same shift or on the basis of maximum working load 30 persons/min.

2 OPERATION CONDITIONS

The turnstile housing with regard to resistance to environmental exposure complies with GOST 15150, category U2 (for an outdoor sheltered application or in premises without climate control). This is ensured by additional corrosion-resistant zinc coating of the housing and by the built-in heating system with thermocontrol. The barrier arms are made of stainless steel as standard.

Operation of the turnstile housing is allowed at ambient air temperature from -40°C to +50°C and at relative air humidity of up to 98% at +25°C.

The RC panel with regard to resistance to environmental exposure complies with GOST 15150, category NF4 (operation in premises with climate control).

Operation of the RC panel is allowed at ambient air temperature from +1°C to +40°C and at relative air humidity of up to 80% at +25°C.

3 TECHNICAL SPECIFICATIONS

Power supply:

turnstile input voltage	12±1.2 DCV
operating voltage of the heating system with thermocontrol	24±2.4 ACV

Consumption current:

of the turnstile (without heating system with thermocontrol)	max. 0.7 A
of the heating system with thermocontrol	max. 2.5 A

Power consumption:

of the turnstile (without heating system with thermocontrol)	max. 8.5
of the heating system with thermocontrol	max. 60

Throughput rate:

in the single passage mode	30 persons/min
in a free passage mode	60 persons/min

Passageway width 600 mm

Barrier arm rotation force max. 5 kgf

RC panel cable min. 6.6¹ m

Electric shock protection class III (IEC 61140)

Ingress Protection Rating IP42 (EN 60529)

Mean time to failure min. 4,000,000 passages

Mean lifetime min. 8 years

Turnstile housing overall dimensions (L x W x H) 855x810x1050 mm

Turnstile housing in assembly, net weight max. 37 kg

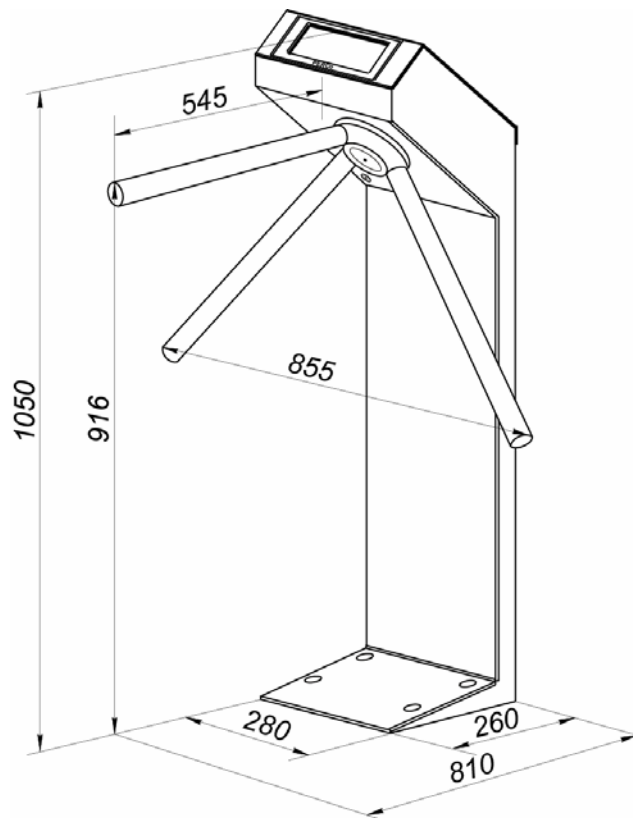

Figure 1. Turnstile overall view

¹ Maximum allowable cable length is 40 m (available on request).

4 DELIVERY SET

4.1 Standard delivery set

Basic equipment:

Turnstile housing	1
Barrier arm ¹	3
RC panel with cable	1
Mechanical release key	2

Installation tools:

Plastic plug	5
Nylon cable tie 100 mm	5

Operational documentation:

Certificate	1
Operation manual	1

Packaging:

Box	1
-----------	---

4.2 Optional equipment supplied on request

Turnstile power supply	1
Power supply of the heating system, 24 ACV	1
WRC kit ²	1
Intrusion detector	1
Siren (for alerts on unauthorized entry attempts)	1
Anchor bolt (SORMAT PFG IR 10-15, Finland)	4

¹ Barrier arm itemized separately in the price list, type is chosen by a Client at the time of order.

² WRC kit consists of a receiver and transmitter (tag) with operation range up to 40 m.

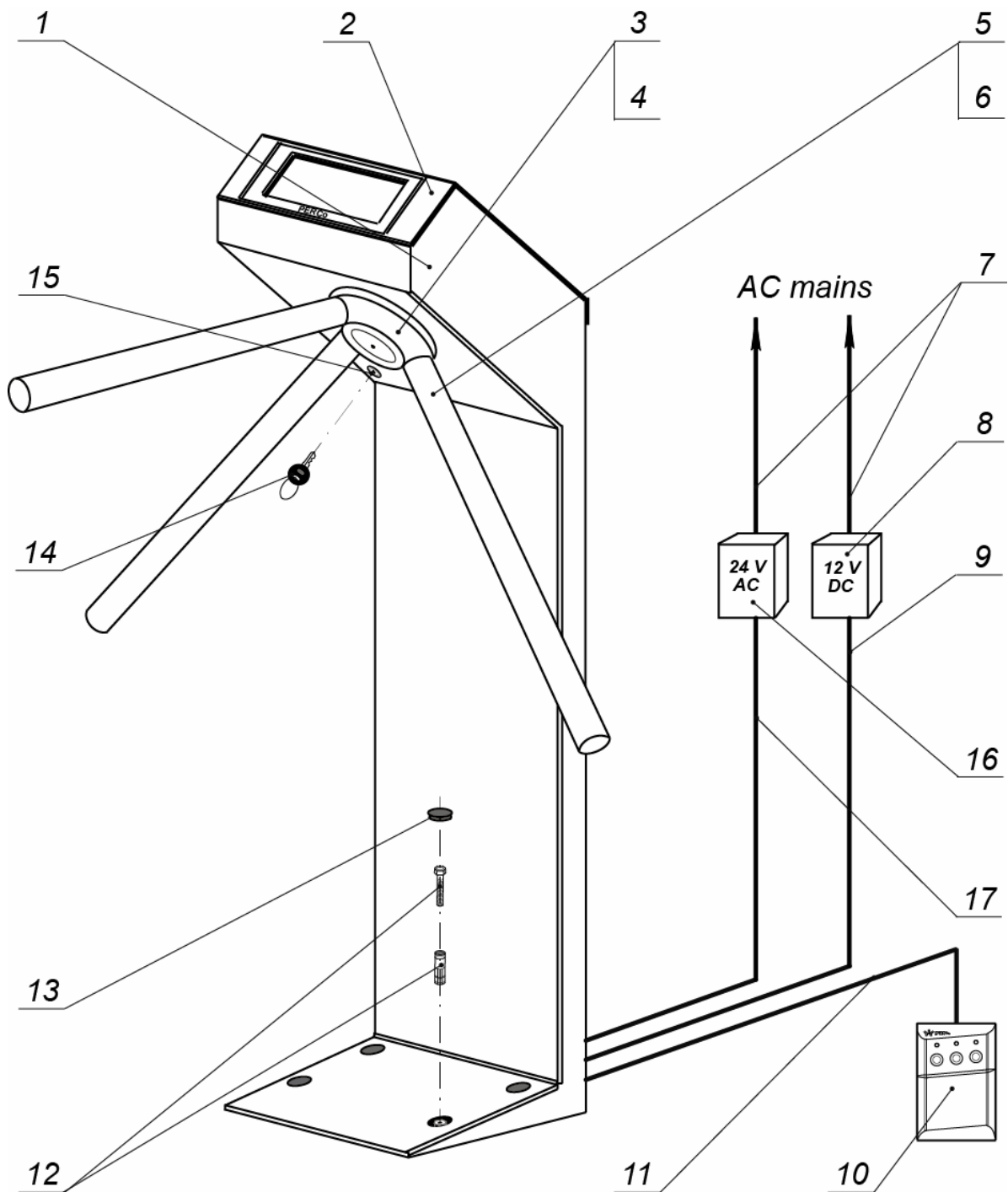

Figure 2. TTR-04CW overall view

- 1 – turnstile housing; 2 – cover with LED indication display; 3 – hub;
 4 – rotation mechanism; 5 – barrier arm; 6 – screw M8 for mounting the barrier arm;
 7 – AC power cables¹; 8 – turnstile power supply unit¹; 9 – turnstile power cable¹;
 10 – RC panel / WRC¹ / ACS controller¹;
 11 – cable of the RC panel / WRC / ACS controller¹; 12 – anchor bolt¹; 13 – plug;
 14 – mechanical release key; 15 – mechanical release lock;
 16 – power supply unit of the heating system¹; 17 – heating system power cable¹.

¹ Available upon request.

5 PRODUCT DESCRIPTION

5.1 Main features

- The turnstile can be operated from the RC panel or WRC kit as well as from an ACS.
- The turnstile is designed either for indoor application or outdoor under shelter (see Clause 2) and is equipped with a heating system with thermocontrol.
- The turnstile retains the set position for each direction when the power is switched off — the open passage direction remains open, the locked passage direction remains locked.
- The mechanical release lock built into the turnstile housing ensures the turnstile unlocking with a key in emergency cases (free rotation of barrier arms).
- The turnstile has relay outputs for connection of an intrusion detector and a siren.
- The turnstile has outputs for connection of remote indicators.
- A purpose-designed “Fire alarm” control input is intended for unlocking the turnstile at the fire alarm command or from emergency unblocking button.
- There are two modes for the turnstile control — a pulse control mode and a potential control mode.
- After each passage the turnstile provides automatic complete rotation of the barrier arms to home position, i.e. automatic reset.
- Smoothness of reset and quiet operation are ensured by a damper.
- The optical arm rotation sensors are built into the turnstile housing to ensure accurate count of inputs to an ACS.
- The turnstile is supplied with safe voltage — maximum 14 V, with the heating system with thermocontrol in operation — no more than 40 V.
- The turnstile has low power consumption — maximum 8.5 W, with the heating system with thermocontrol in operation – maximum 70 W total.
- Galvanic decoupling of the outputs ensures noise-immunity of the turnstile electronics.

5.2 Design

The design of the turnstile is shown in Fig. 2. Numbers in brackets correspond to Fig. 2 of this Manual.

5.2.1 The turnstile housing (1) is a welded metal structure with a cover (2). In an upper part of the turnstile housing there is a rotation mechanism (4) with three barrier arms (5), a locking device, a self-centering mechanism and arm rotation sensors. A LED indication display is located on the front panel of the cover (2). The turnstile housing is equipped with the heating system with thermocontrol.

5.2.2 The large LED indication display with bright pictograms is intended for status and direction indication: a Green Arrow indicates the direction of an authorised passage (the turnstile is open in the set direction); a Red Cross indicates ban on passage (the turnstile is locked).

In the left-hand bottom corner of the LED indication display of the turnstile housing there is an additional LED indicating operating modes of the built-in heating system with thermocontrol. The LED is green when the heating system with thermocontrol is powered up, and it is amber when the heater is in operation).



Figure 3. LED indication display

5.2.3 The RC panel/ WRC/ ACS controller (10) and the turnstile power supply unit (8) are connected to the CLB with the cables (9 and 11) in accordance with the connection layout (see Fig. 6).

5.2.4 The RC panel is designed as a small desktop device with a shockproof ABS plastic case and is intended for setting and indicating operating modes when the turnstile is operated manually. The RC panel is connected to the CLB with a multicore cable (11) via the XT1.L connector block (See Fig. 4).

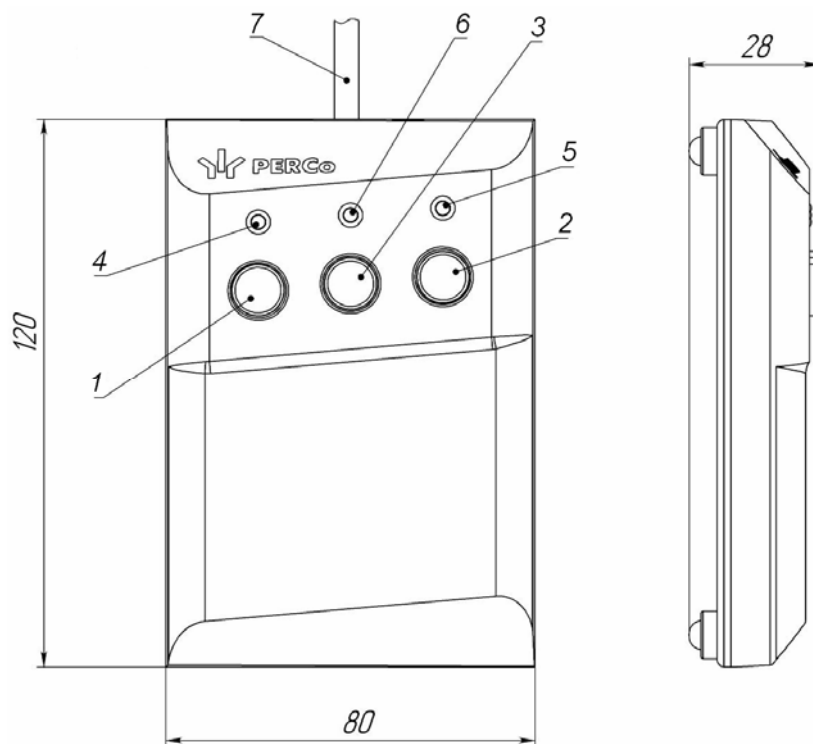

Figure 4. RC panel overall view

- 1, 2, 3 – buttons **LEFT**, **RIGHT**, **STOP** for setting the passage mode;
- 4, 5 – green indicators «*Left*», «*Right*»;
- 6 – red indicator «*Stop*», 7 – RC cable.

There are three control buttons on the RC front panel intended for setting the turnstile operating modes. The LED indicators are located above the buttons. The middle button on the RC panel (hereinafter — the **STOP** button) is intended to set the turnstile to the “Always locked” mode. The left and the right buttons are intended to unlock the turnstile for passage in the chosen direction.

The RC panel is connected to the CLB with a multicore cable (6) via the “XT1.L” connector block (Ref. Fig. 5 and 6).

If the turnstile orientation relatively to the operator’s terminal is not standard (e.g. the terminal is placed at the backside of the turnstile housing), the RC panel orientation towards the turnstile can be changed by exchanging places of the RC wires to the contacts *Unlock A* and *Unlock B* as well as contacts *Led A* and *Led B* accordingly (see Fig. 5 and Fig. 6).

5.2.5 The CLB (Fig. 5) contains:

- **X1 (Control)** – connector to connect the control mechanism (connected to the “X1” connector of the control mechanism with the turnstile cable);
- **XT1.L (In)** – connector block to connect the RC panel / WRC / inputs of an ACS controller as well as an emergency unblocking device;
- **XT1.H (Out)** – connector block to connect a siren and outputs providing the turnstile status data to the ACS controller;
- **XT2 (Detector)** – connector block to connect an intrusion detector;
- **XT3 (+12VDC)** – connector block to connect the turnstile power supply;
- **XT4 (Light A)** and **XT5 (Light B)** – connector blocks to connect “Open/closed” light indicators, one pair per each direction;
- **J1** – connector to select the turnstile control mode;
- **J2** – connector for programming.

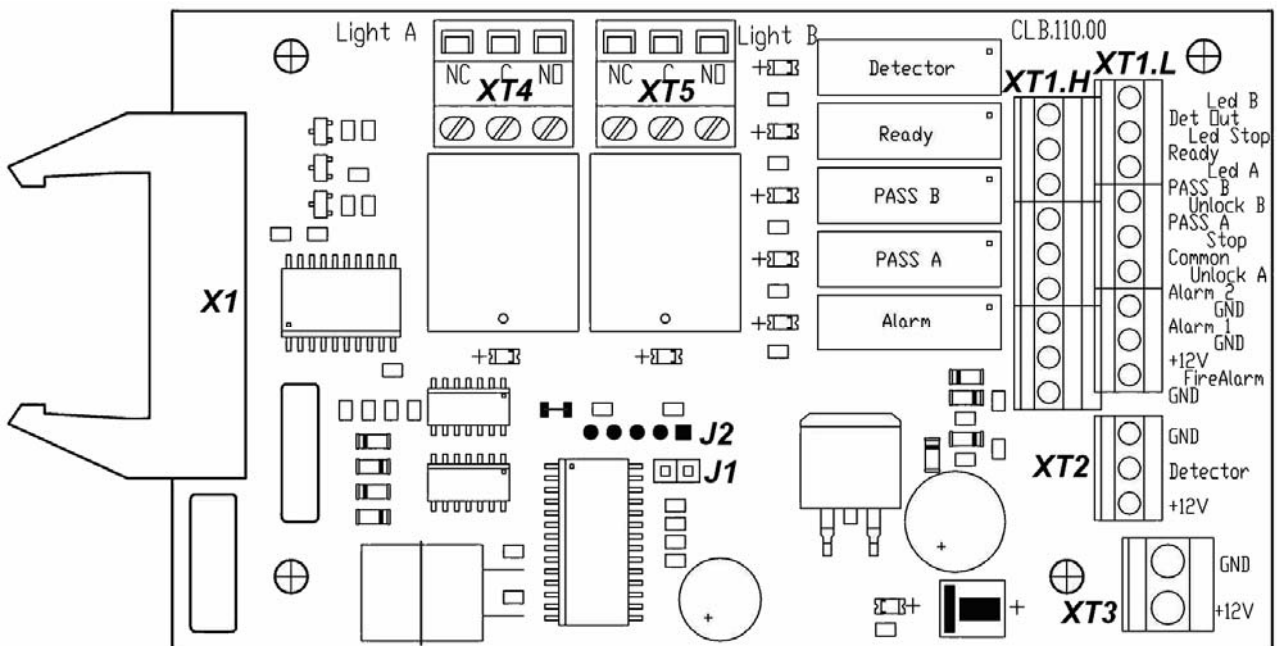

Figure 5. Control Logic Board (CLB)

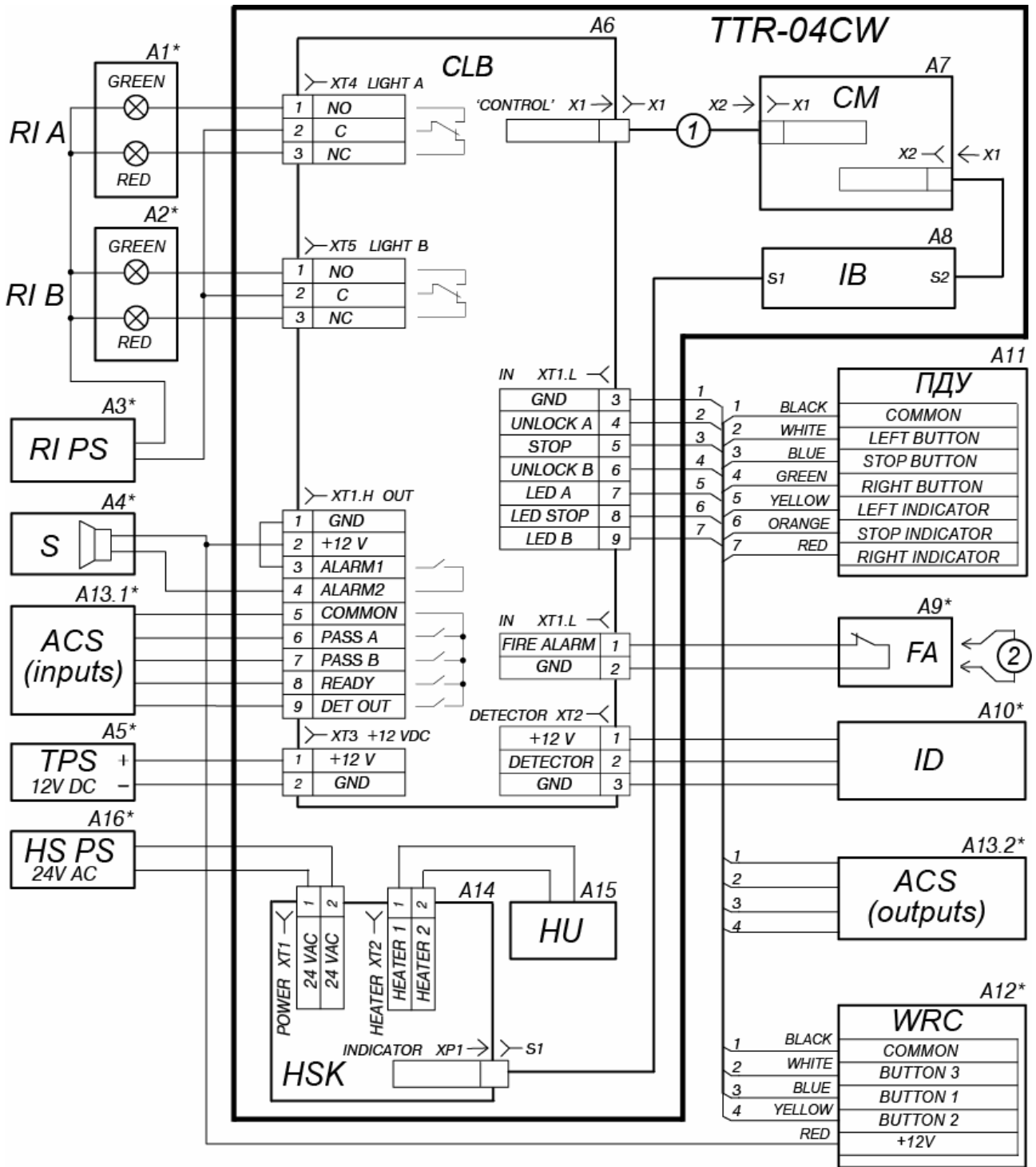

Figure 6. Connection layout

Table 1. Legend to Fig. 6

Legend	Item	Q-ty	Note
A1*, A2*	Remote indicators for directions of A and B	2	
A3*	Remote indicator power supply	1	
A4*	Siren	1	12 V DC
A5*	Turnstile power supply	1	12V DC, 1A
A6	CLB	1	CLB-110
A7	Control mechanism	1	
A8	Indication module	1	
A9*	Emergency unblocking device (Fire Alarm)	1	
A10*	Intrusion detector	1	CLIP-4
A11	RC panel	1	H6/4
A12*	Wireless remote control kit	1	MSRF-4
A13*	Access control system	1	
A14	Heating system controller	1	
A15	Heating unit	1	
A16*	Heating system power supply	1	24V AC, 2.5A
1	Turnstile cable	1	
2	Wire jumper. Installed when the emergency unblocking device (A9) is not connected	1	Installed on default

* Available upon request

5.3 Control over the turnstile

5.3.1 The turnstile can be operated from the following control devices:

- the RC panel;
- the WRC;
- the ACS controller.

The above devices can be connected to the turnstile as follows:

- any device separately;
- in any combination with each other;
- all devices simultaneously (in parallel).



Note:

At the parallel connection of the above devices to the turnstile the superposition of the control signals from them may occur. In that case the turnstile response will conform to response to the obtained combination of input signals (Appendices A and B).

5.3.2 Connection of the devices stated in Clause 5.3.1 is made with the cable (11) to the corresponding connector blocks *XT1.L* or *XT1.H* of the CLB in accordance with the connection layout (Fig. 5 and 6).

5.3.3 The RC panel is connected to the contacts *GND*, *Unlock A*, *Stop*, *Unlock B*, *Led A*, *Led Stop* and *Led B* of the *XT1.L* connector block.

5.3.4 The WRC kit is connected to the contacts *GND*, *Unlock A*, *Stop* and *Unlock B* of the *XT1.L* connector block. Power supply of the WRC is connected to the contact *+12V* of the *XT1.H* connector block.

5.3.5 The ACS controller outputs are connected to the contacts *GND*, *Unlock A*, *Stop* and *Unlock B* of the *XT1.L* connector block.

5.3.6 The ACS controller inputs are connected to the contacts *Common*, *PASS A*, *PASS B*, *Ready* and *Det Out* of the *XT1.H* connector block.

5.3.7 Pin assignments of the CLB connector blocks are given in Fig. 5 and on a label located on the inner surface of turnstile cover (2) with LED indication display (2).

5.4 Input and output control signals and their parameters

5.4.1 The CLB microcontroller processes the incoming commands (i.e. traces the status of the contacts *Unlock A*, *Stop*, *Unlock B* and *Fire Alarm*), keeps track of the signals from the optical arm rotation sensors and from the intrusion detector (contact *Detector*) and basing on those signals, generates commands to the control mechanism and to the external devices – indication on the RC PANEL (*Led A*, *Led Stop* and *Led B*), the signal of hub turning in the corresponding direction (*PASS A* and *PASS B*), the signal of the turnstile ready for a current command (*Ready*), the alarm output signal (*Alarm*) and relays the signal of the current status of the intrusion detector (*Det Out*).

5.4.2 The turnstile is operated by input of a low-level signal to the *XT1.L* connector block contacts *Unlock A*, *Stop* and *Unlock B* relatively to the *GND* contact. As the control element there can be used a normally open relay contact or a circuit with open collector output at that. At the emergency the turnstile control is carried out by removing of a low-level signal from the *Fire Alarm* contact relatively to the *GND* contact. As the control element there can be used a normally closed relay contact or a circuit with open collector output at that (Fig. 7 and 8).



Note:

For generating of a high-level signal at all the input contacts (*Unlock A*, *Stop*, *Unlock B*, *Fire Alarm* and *Detector*) 2kOhm resistors connected to the power supply bus + 5 V are used.

the relay contact as the control element:

minimum switched current..... no more than 2 mA
 closed contact resistance (with the resistance
 of the connected cable) no more than 300 Ohm

the circuit with open-collector output as the control element:

voltage at the closed contact
 (low - level signal at the CLB input) no more than 0.8 V

5.4.3 The relays *PASS A* (contacts *PASS A* and *Common*), *PASS B* (contacts *PASS B* and *Common*), *Ready* (contacts *Ready* and *Common*), *Detector* (contacts *Det Out* and *Common*) and *Alarm* (contacts *Alarm 1* and *Alarm 2*) have normally open contacts. The *Common* contact, at that, is not connected to the CLB power supply negative terminal. In the initial (inactive) state, when the power is on, the relay contacts *PASS A*, *PASS B*, *Ready* and *Detector* are closed (voltage is supplied to the relay coil) and the *Alarm* relay contacts are broken (voltage is not supplied to the relay coil). The CLB relay operation/release is indicated by lighting up/going down of the red test indicators located near the corresponding relays (Fig. 5).

The output cascades for *PASS A*, *PASS B*, *Ready*, *Det Out* and *Alarm* are the contacts with the following signal characteristics (Fig. 9):

maximum commutation voltage..... 42 V DC
 maximum switched current 0.25 A
 closed contact resistance no more than 0.15 Ohm

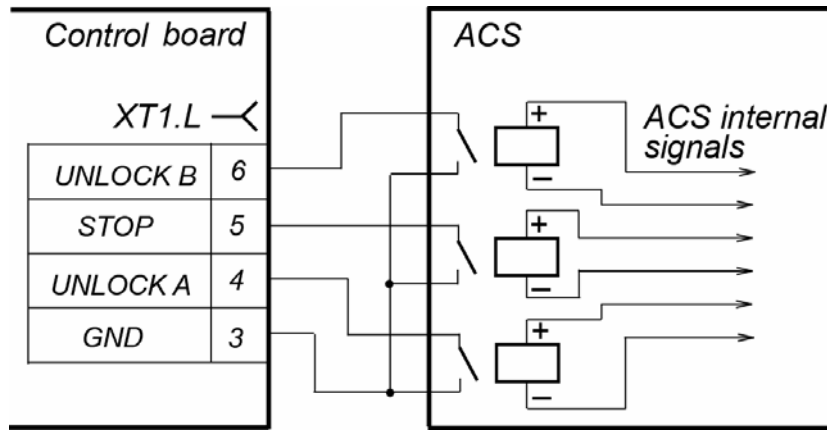

Figure 7. ACS control element — normally open relay contact

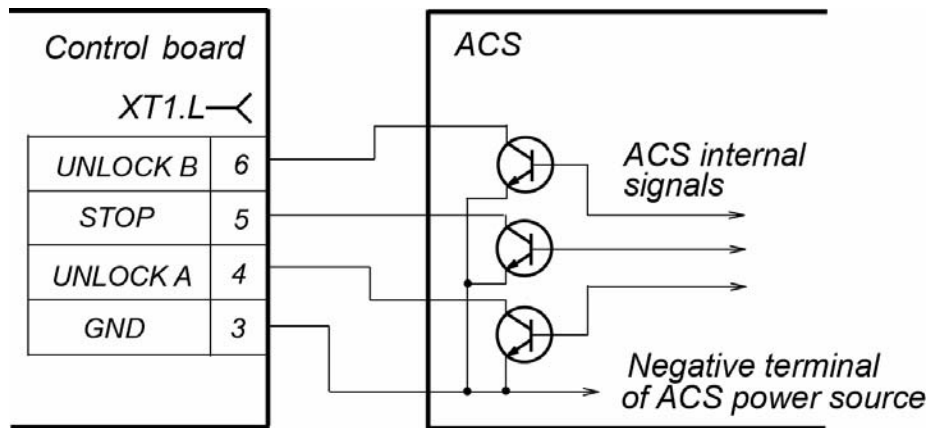

Figure 8. ACS control element — circuit with open-collector output

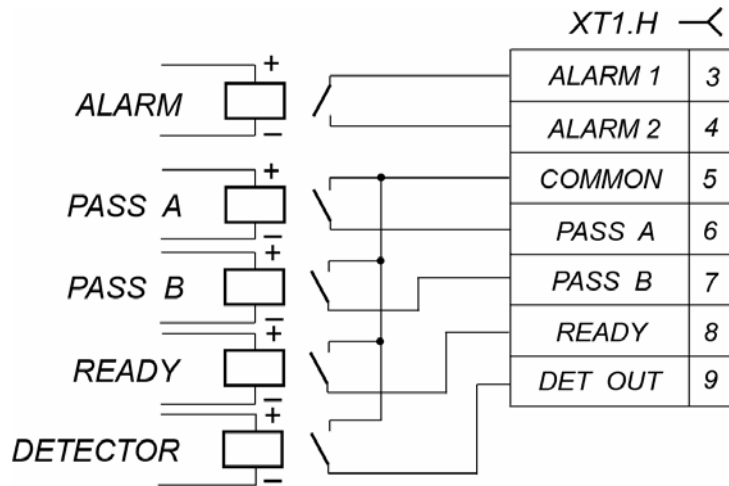

Figure 9. Output cascades for PASS A, PASS B, Ready, Det Out and Alarm

5.5 Control modes

5.5.1 There are two modes of the turnstile control - a **pulse control mode** and a **potential control mode**. They determine available **operating modes** of the turnstile (Table 2 and Table 3).

5.5.2 The control mode is set by the jumper on the J1 connector (the J1 connector location is shown on Fig. 5 and on a label located on the inner surface of turnstile cover (2): the jumper is fixed — the pulse control mode, the jumper is not fixed – the potential control mode. The jumper is fixed at the factory before the delivery.

5.5.3 Control over the turnstile is effected by input of the control signal to the turnstile at both control modes. The passage waiting time in the pulse control mode is 5 seconds regardless of the control signal length. In the potential control mode the passage waiting time equals the length of the control signal.

5.5.4 The pulse control mode is intended for the turnstile operation from the RC panel, the WRC or the ACS controller, outputs of which support the pulse control mode.

Standard control inputs: *Unlock A*, *Stop* and *Unlock B*.

Special control input: *Fire Alarm*.

See Table 2 for the turnstile operating modes at this control mode. The algorithm of control signals at this mode is stipulated in Appendix A.

The minimum input signal duration, when the operating mode can be changed, should be 100 msec. The passage waiting time is 5 sec. and it does not depend on the input signal duration.

See Clause 5.9.3.1 for the turnstile operation at special *Fire Alarm* control input.

5.5.5 The potential control mode is intended for the turnstile operation from the ACS controller, outputs of which support the potential control mode (for example, a lock controller).

Standard control inputs: *Unlock A* and *Unlock B*.

Special control inputs: *Stop* and *Fire Alarm*.

See Table 3 for the turnstile operating modes at this control mode. The algorithm of control signals at this mode is stipulated in Appendix B.

The minimum input signal duration, when the operating mode can be changed, should be 100 msec. The passage waiting time is equal to the low-level signal duration (the turnstile remains open in the set direction if a low-level signal exists at the set direction input by the moment of passage).

At the low-level signal inputting to the *Stop* input, both directions are locked for the time of the signal duration regardless the signal strength at the inputs *Unlock A* and *Unlock B*. At the low-level signal removing from the *Stop* input, the directions are set to the control mode according to the signal strength at the inputs *Unlock A* and *Unlock B*.

See Clause 5.9.3.2 for the turnstile operation at the special *Fire Alarm* control input.

5.6 Operation with RC panel

5.6.1 When the buttons on the RC panel are pressed (the **STOP** button and the two other buttons corresponding to the passage direction), the closing of the relevant contact *Unlock A*, *Stop* or *Unlock B* to the contact *GND* occurs (i.e. forming of the low-level signal relatively to the contact *GND*).

5.6.2 Operation logic of the turnstile at the single passage in the A(B) direction at the pulse control mode:

5.6.2.1 When the button, corresponding to the A(B) passage direction, is pressed on the RC panel, the closing of the contact *Unlock A(B)* to the contact *GND* occurs (i.e. forming of the low-level signal on the contact *Unlock A(B)* relatively to the contact *GND*).

5.6.2.2 The CLB microcontroller processes the incoming command and generates the command to the control mechanism, which opens the A(B) passage direction (lifts the upper (lower) edge of the key holt).

5.6.2.3 The microcontroller traces the status of the optical arm rotation sensors, which become active/passive in a certain consequence at the barrier arm rotation, and counts the time passed since the moment of pushing the RC button corresponding to the permitted passage direction A (B).

5.6.2.4 At the barrier arms turning at 67° the microcontroller forms signal *PASS A(B)* (breaking the contacts *PASS A(B)* and *Common* takes place).

5.6.2.5 After the barrier arms turning at 67° or after 5 seconds since the moment of pushing the RC button corresponding to the permitted passage direction A (B), the microcontroller generates a command to the control mechanism, which closes the passage direction A (B) (drops down the upper (lower) edge of the key holt).

5.6.2.6 When the barrier arms reset to home position (barrier arms turning at 112°), the microcontroller removes the signal *PASS A(B)* (contacting the *PASS A(B)* and *Common* takes place).

5.6.3 The “Always free” operating mode particularity: in this mode the command described in Clause 5.6.2.5 is not generated and the set passage direction remains open.

5.7 Operation with WRC

5.7.1 Control over the turnstile with the WRC is similar to that with the RC panel.

5.7.2 The buttons on WRC tag act the same way as those on the RC panel.

5.7.3 The WRC operation manual is supplied with that device.

5.8 Operation with ACS controller

5.8.1 In the pulse control mode control over the turnstile with an ACS controller is similar to that with the RC panel.

5.8.2 In the potential control mode control over the turnstile with an ACS controller is similar to that with the RC panel and lies in forming of low-level signal on the contacts *Unlock A*, *Stop* and *Unlock B* relatively to the contact *GND*.

5.8.3 The difference of the operation logic in the potential control mode and in the pulse control mode (as per Clause 5.6.2 the command described in Clause 5.6.2.5 is generated **only** at the moment of releasing the RC button, corresponding to the passage direction A(B). Therefore, for arranging single passages in the potential control mode it is recommended to remove the control low-level signal at the beginning of the *PASS* signal for the corresponding direction.

5.8.4 The passage through the turnstile in the A (B) direction is fixed in accordance with the status of the output contacts *PASS A(B)* and *Common*.

5.9 Optional external devices connected to the turnstile

5.9.1 The following external devices can be connected to the turnstile

- intrusion detector and siren;
- emergency unblocking device;
- remote indicators.

5.9.2 The intrusion detector is connected to the *XT2* connector block, and the siren is connected to the *XT1.H* connector block of the CLB according to the connection layout (Fig. 5 and 6). There should be normally closed contacts on the intrusion detector.



Attention!

Only the manufacturer should carry out the installation of the intrusion detector on the turnstile housing.

If the turnstile is locked (the “Always locked” mode /“Both directions closed” mode when both directions are locked, Tables 2 and 3) and a signal comes from the intrusion detector, the “Alarm” signal is generated. The “Alarm” signal is disabled after 5 sec. or by executing of any received command. The signal from the intrusion detector is ignored for the period of authorized unlocking of the turnstile in either or both directions.

If within 3 sec. after the “Always locked”/“Both directions closed” mode is set, the signal from the intrusion detector comes, it is also ignored.

The intrusion detector status signal is constantly transmitted to the *Det Out* and *Common* contacts of the CLB *XT1.H* connector block (Fig. 5).

5.9.3 The emergency unblocking device is connected to the *XT1.L* connector block of the CLB in accordance with the connection layout (Fig. 5 and 6). If the *Fire Alarm* input is not used, it is necessary to set a jumper between the contacts *Fire Alarm* and *GND*. This jumper is preset at the factory.

Operation of the turnstile under commands of the emergency unblocking device:

5.9.3.1 In the pulse control mode, when a low-level signal is removed from the *Fire Alarm* input, both passage directions become open for the whole period of the signal absence. Other control commands are ignored at that. When the low-level signal appears at the *Fire Alarm* input, the turnstile turns to the “Always locked” mode.

5.9.3.2 In the potential control mode, when a low-level signal is removed from the *Fire Alarm* input, both passage directions become open for the whole period of the signal absence. Other controlling commands are ignored at that. When the low-level signal appears at the *Fire Alarm* input, the passage directions turn to the mode in accordance with the signal levels at the inputs *Unlock A*, *Unlock B* and *Stop*.

5.9.4 The remote indicators are connected to the connector blocks *XT4* (Light A) and *XT5* (Light B). At that the “Light A” (“Light B”) relay is active (the voltage is supplied to the relay coil), when the “Green arrow” pictogram on the LED indication display, corresponding to the set passage direction, lights, and it is passive, when the “Green arrow” pictogram on the Led display does not light. The response/release of the relays “Light A” and “Light B” can be defined according to lighting up/going down of the red indicators, which are installed near the above mentioned relays (Fig. 5). Output cascades for the “Light A” and the “Light B” relays are nonbridging relay contacts (Fig. 10) with the following signal characteristics:

- maximum switched voltage 30V DC;
- maximum switched voltage 42V AC;
- maximum switched AC/DC 3 A;
- closed contact resistance no more than 0.15 Ohm.

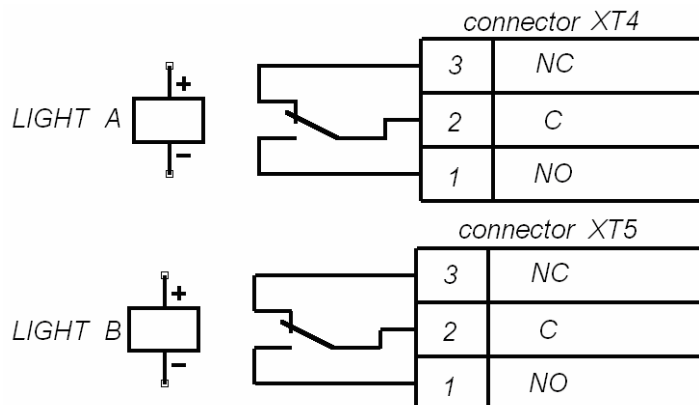

Figure 10. Output cascades for Light A and Light B

5.10 Key override control

5.10.1 The key override option allows an operating technician to unlock both directions of the turnstile if there is need to override the access control system or in case of emergency or power failure.

5.10.2 To unblock the turnstile it is necessary to insert the key (14) into the lock (15), turn it at 90° clockwise and then take out. Then the barrier arms can be freely turned in both directions.

5.10.3 Deactivating mechanical unblocking of the turnstile in the following order:

- install barrier arms to the starting position;
- click on the lock mechanism mechanical release, sinking it into the housing until it clicks;
- make sure that the turnstile is locked, and the barrier arms do not rotate in any direction.

5.11 Operation contingencies and response

5.11.1 The turnstile is capable of providing information on the following operation contingencies:

- unauthorized access;
- passage delay for more than 30 sec;
- one or both optical arm rotation sensors are out of order.

A special signal “Ready” is generated in each of the above cases.

5.11.2 In case of unauthorized access the “Ready” signal is formed as follows: at 8° arm rotation one of the optical sensors (Fig. 13) responds and the output contacts *Ready* and *Common* get broken (the beginning of the signal). When the barrier arms reset to home position, the both optical sensors become passive and the output contacts *Ready* and *Common* get closed (the finish of the signal).

5.11.3 In case of delay of an authorized passage for more than 30 sec. the signal “Ready” is formed as follows: if within 30 seconds from the moment of passage commencing, which is determined by the arm rotation at no less than 8° (i.e. activation of one of the optical sensors), the reset of barrier arms to home position does not happen, the output contacts *Ready* and *Common* break (the beginning of the signal). When the barrier arms reset to home position, the both optical sensors become passive and the output contacts *Ready* and *Common* are closed (finish of the signal).

5.11.4 When one or both of the optical sensors become out of order, the output contacts *Ready* and *Common* get broken (the beginning of the signal “Ready”). After fault removal the closed status of the contacts *Ready* and *Common* is renewed.

6 MARKING AND PACKAGING

The turnstile has the marking on the turnstile housing in the form of a label located on the inner panel of the turnstile housing. The label contains manufacturer's trademark and contact details, year and month of production, operating voltage and power consumption of the turnstile.

To get access to the label it is necessary to take off the turnstile cover (2) in the following way:

1. Unscrew the fixing bolts of the cover using the S10 socket wrench. The fixing bolt of the cover is located beneath the hub (3), close to the lock (15).
2. Carefully lift up the cover with the LED indication display (2) by turning it in direction of the display. Please pay attention for not to break the inner cables.
3. Disconnect the cable connectors S1 and S2 connecting the cover with turnstile housing.
4. Carefully take off the cover and lay it on a plain and steady ground.

The complete delivery set of the turnstile (Chapter 4.1) is packed in a transportation box, which keeps it undamaged during the transportation and storage.

Box overall dimensions (length × width × height) 114×32×32 cm
Gross weight max. 42 kg

7 SAFETY REQUIREMENTS

7.1 Installation safety requirements

The installation should be only carried out by the qualified personnel after the careful study of this Manual.



Caution!

- All the cables should be connected up when the power supply is switched off from the AC mains.
- Use only the serviceable tools for installation.
- Observe general electrical safety rules when laying out the cables.

See certificates of the power supply units for the safety requirements to those power supply units.

7.2 Operation safety requirements

Observe general electrical safety rules when operating the turnstile.



Do not use!

- Do not use the turnstile under conditions that do not comply with the requirements of Chapter 2 of this Manual.
- Do not use the turnstile at supply voltage that does not comply with the requirements of Chapter 3 of this Manual.

See certificates of the power supply units for the safety requirements to those power supply units.

8 INSTALLATION INSTRUCTIONS

8.1 Installation details

It is recommended:

- to mount the turnstile on steady and level concrete (grade 400 or higher, strength group V22.5), stone or similar foundations at least 150 mm thick;
- to level the foundation so that the anchoring points of the turnstile lie in the same plane (to be verified with a builder's level);
- to apply reinforcing elements (300×300×300 mm) for installation on less steady foundation;
- to organize the passage zone according Fig. 11;
- to mark the mounting holes according to Fig. 12;
- to control the vertical position of the turnstile during installation
- to arrange additional emergency exit;
- when creating the passage area through the turnstile take into account that the resetting device operates as follows:
 - at the barrier arm turning at the angle of more than 60° the reset is effected in the direction of movement;
 - at the barrier arm turning at the angle less than 60° the reset is effected in the counter to the movement direction (reset to home position).



Note:

The angle gradient, at which the barrier arm reset commences, may vary in the range of $\pm 5^\circ$.

To ensure accurate passage tracking, when the turnstile is operated from an ACS, it is recommended to create the passage area in such a way that the barrier arms should turn in the direction of movement at the angle no less than 70° (Fig. 11).

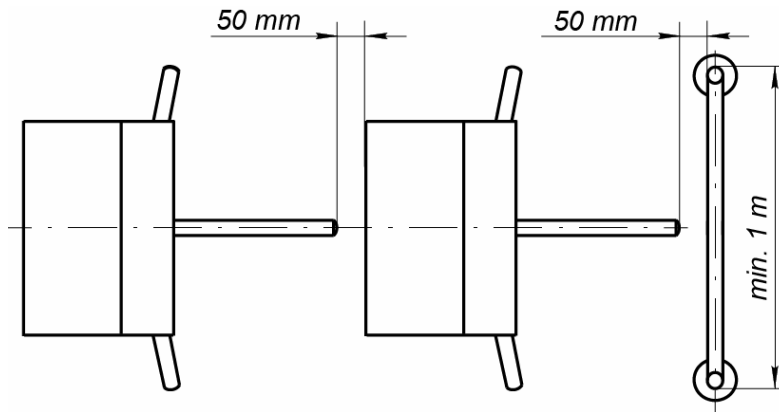

Figure 11. Site preparation. Recommendations

8.2 Installation tools

- 1.2÷1.5 kW hammer drill;
- Ø16mm hard-alloyed drill bits;
- Floor chaser for electric raceway;
- Cross-head screwdriver No.2;
- Flat slot screwdriver No.5 (150mm);
- Flat slot screwdriver No.2
- Horn-type and socket wrenches S17, S13, S10, S8, S7;
- Plumb line and level;

- Hard wire 1.5 m long for cable pulling.
- Measuring tape (2 m);
- Slide caliper.



Note:

It is allowed to use other testing equipment and measuring tools provided the equipment in use ensures the required parameters and measurement accuracy.

8.3 Cable length

The maximum allowed length of the RC panel/ WRC/ ACS controller cable is no more than 40 m.

The maximum allowed length of the turnstile power cable depends on the cable cross-section and should be:

for cable with 0.2 mm ² (AWG 24)	max. 10 m
for cable with 0.75 mm ² (AWG 18)	max. 25 m
for cable with 1.5 mm ² (AWG 16)	max. 50 m

The maximum allowed length of the heating system power cable depends on the cable cross-section and should be:

for cable with 0.75 mm ² (AWG 24)	max. 20 m
for cable with 1.5 mm ² (AWG 18)	max. 40 m

8.4 Installation procedure



Attention!

The manufacturer shall not be liable for any damage caused as the result of improper installation and declines any claims arising thereof in case if the installation is not done in compliance with the instructions provided in this Manual.

The turnstile connection layout is given in Fig. 6. The CLB connectors location is shown in Fig. 5. Cables parameters and their length are given in clause 8.3. The installation surface and passage area recommendations are given in clause 8.1.

1. Unpack the turnstile check the completeness as per Chapter 4.
2. Make the holes for anchor bolt (12) sleeves for the turnstile housing installation (Fig. 12).
3. Install the turnstile power supply unit (8) in its place (See power supply unit certificate for installation procedure of the turnstile power supply).
4. If you lay out cables under the floor surface, make an electric raceway to the cables entry zone of the turnstile housing (shown in Fig. 12).
5. Insert sleeves for anchor bolts into the holes so that they do not stick out above the floor surface.
6. Remove the cover (2) in order given in Chapter 6.
7. Lay the cables in the electric raceway and inside the turnstile housing.
8. Insert sleeves for anchor bolts into the holes so that they do not stick out above the floor surface. Set up the housing and fix it with the M10 bolts.



Caution!

Fix the housing after laying the cables in the electric raceway and inside the turnstile housing. Be careful and prevent the turnstile from falling before it is fixed.

9. If it is necessary to set up the turnstile into potential control mode remove the jumper on the **J1** connector of the CLB.

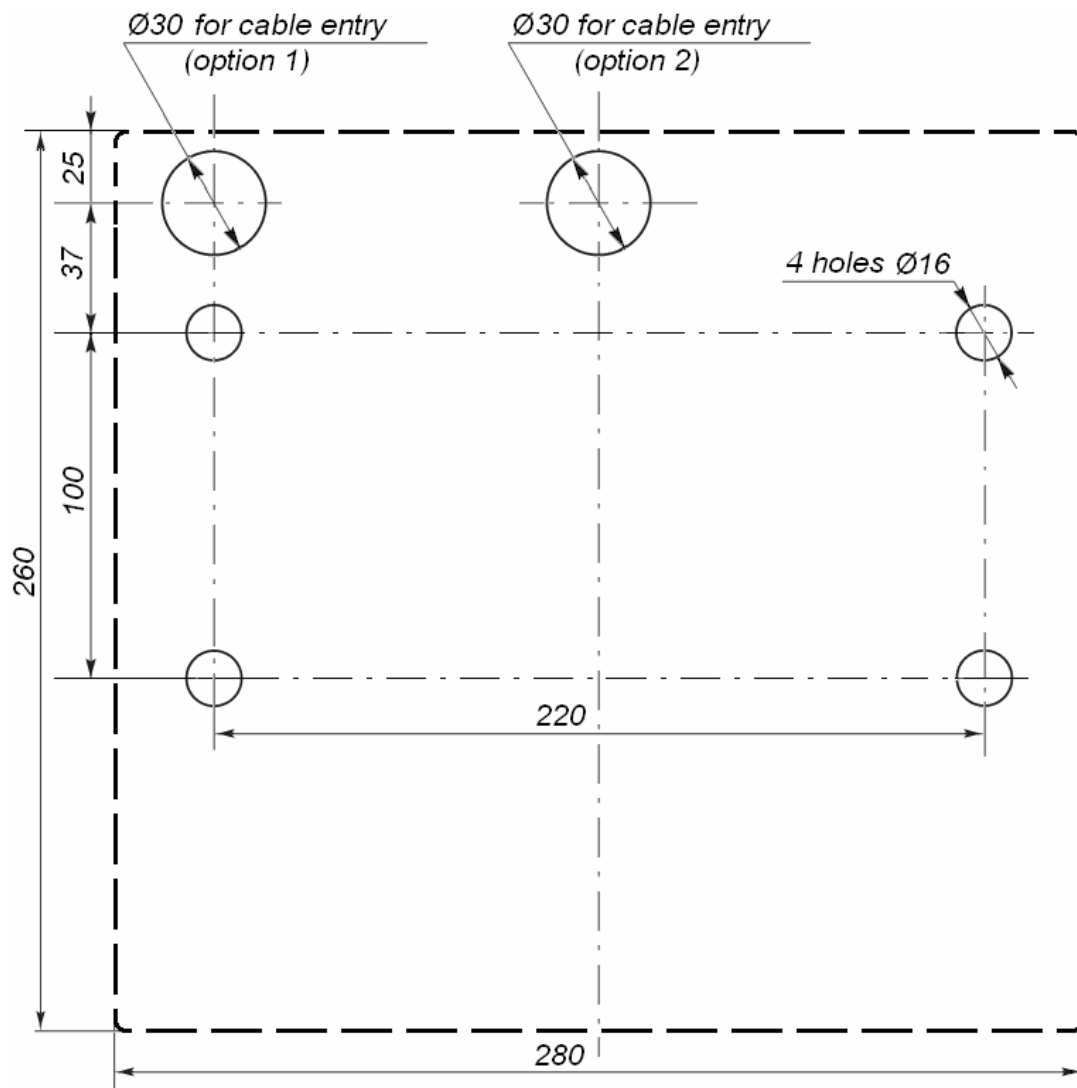

Figure 12. Floor anchor position and cable entries for housing installation

10. Connect the RC panel cable (11) (WRC / ACS controller) to **XT1.L** connector block.
11. Connect the additional equipment if necessary (intrusion detector and a siren; emergency unblocking device (*Fire Alarm*); remote indicators).
12. Connect the power cable (9) from the turnstile power supply to **XT3** connector block, and also connect the cable from the power source heating system according to Fig. 6.
13. Check serviceability and accuracy of all the electrical connections. Fasten all the cables in two points to the hole in the turnstile housing horizontal plane, using hook and loop cable ties.
14. Connect S1 and S2 cable connectors connecting the indication board of the cover with the board in the housing. Mount the cover with LED indication back into its place in the reverse order. When the cover with LED indication display mounting is carried out correctly it does not need much effort. Fasten the cover with the bolts.
15. Install the plugs (13).
16. To mount the barrier arms into the run position, remove the cover from the hub (3) after unscrewing the screw. Unscrew the bolt (6), on the barrier arm (5). Fit the barrier arm (5) into the mounting hole on the hub (3) and fasten it with the bolt (6). Put a spring washer under the bolt head. The bolts must be tightened so as to ensure reliable fixation of the barrier arms without a gap.

Run a test switch on of the turnstile as specified in clause 9.1.

9 OPERATION INSTRUCTIONS

Follow the turnstile operation safety requirements (see Clause 7.2).



It is prohibited!

- To move through the turnstile passage area any objects with dimensions exceeding the width of the passageway.
- To jerk hit barrier arms, turnstile housing and light indication display so as to prevent their mechanical deformation.
- To disassemble and regulate turnstile components.
- To use abrasive or chemically active substances for cleaning of the turnstile external surfaces.

9.1 Power-up

Follow these steps:

1. Connect the AC power cable (7) of the turnstile power supply (8) to the AC outlet with the voltage and frequency rating according to the certificate for power supply.
2. Switch on the turnstile power supply. At the set pulse control mode, the turnstile switches to «*Always locked*» mode. At the set potential control mode, the turnstile switches to «*Both directions locked*» mode. At the same time the red LED indication display of the turnstile cover showing the ban on passage and the indicator above the **STOP** button on the RC panel (5) light up.
3. Turn on the power supply heating system. When the ambient temperature is below 0°C the heater controller turns on the heating of the internal volume of the turnstile, and the orange indicator lights up on the LED indication display. When heating is finished, the controller switches off the heating and the temperature indication turns off.
4. Check operation of the intrusion detector and siren (if included in the delivery set and installed accordingly). After the power-up wait until the moment of the test indicator (inside the intrusion detector) going off (from 10 to 50 sec). Put your hand before the intrusion detector. The continuous signal will sound when the intrusion detector activates. To eliminate that sound signal press any button on the RC panel. The sound will stop without pressing the button in 5 sec.

The turnstile is ready for operation.

9.2 Turnstile operating modes in pulse control mode

See Table 2 for the operating modes set from the RC panel and for the corresponding indication. Please note the following:

- setting the operating modes for each direction is independent, i.e. setting the operating mode for one direction does not change the operating mode set earlier for the opposite one;
- the “Single passage in the set direction” mode can be changed to the “Always free” mode for the same direction, or to the “Always locked” mode;
- the “Free passage in the set direction” mode can be changed to the “Always locked” mode only.

At the turnstile power supply switching-on the reset state of the turnstile is “Closed” (the mechanical release lock (15) is locked with the key (14) at that).

In the “Single passage in the set direction” mode the turnstile will close automatically after a person’s passage in the set direction. The turnstile will also close automatically, if the passage is not made within 5 sec. In the “Bi-directional single passage” mode after the

passage in one direction the countdown of the passage waiting time (5 sec.) for the opposite direction is recommenced.

Table 2 Pulse control mode (the jumper is set on the J1 connector)

N	The turnstile operating modes	Actions to do	Indication on the RC panel	Indication on the LED display	Turnstile status
1	Always locked (Locked for entry and exit)	Press the STOP button on the RC panel	The red indicator above the STOP button is on	The "Red cross" pictogram is on	The turnstile is locked
2	Single passage in the set direction (open for passage of one person in the chosen direction)	Press the button on the RC panel corresponding to the chosen passage direction	The green indicator above the button of the chosen passage direction is on	The "Green arrow" pictogram, showing the passage direction is on	When the passage is completed, the turnstile is locked
3	Bi-directional single passage (open in both directions for 'one-by-one' passage)	Press both the left and right side buttons on the RC panel simultaneously	The two green indicators (left and right) are on	The two "Green arrow" pictograms (left and right) are on	The turnstile is locked in the direction of completed passage
4	Free passage in the set direction (open for free passage in the chosen direction)	Press the STOP button and the button corresponding to the chosen passage direction simultaneously	The green indicator above the button of the chosen passage direction is on	The "Green arrow" pictogram, showing the passage direction is on	Turnstile remains open in the set direction
5	Free passage in the set direction and single passage in the opposite direction (open for free passage in the chosen direction and for passage of one person in the opposite direction)	Carry out actions stated in Chapters 2 and 4 of the present table in any order	The two green indicators (left and right) are on	The two "Green arrow" pictograms (left and right) are on	After the passage in the free passage direction the turnstile remains open in both directions. After the passage in the single passage direction the turnstile remains open in the free passage direction but it is gets locked in the single passage direction
6	Always free (open for entry and exit)	Press all the 3 buttons on the RC panel simultaneously	The two green indicators (left and right) are on	The two "Green arrow" pictograms (left and right) are on	The turnstile remains open



Note:

Pressing the button on the RC panel corresponds to the low-level signal supply to the contacts (*Unlock A*, *Unlock B* and *Stop*) of the *XT1.L* connector block relatively to the contact *GND*.

9.3 Turnstile operating modes in potential control mode

See Table 3 for the operating modes set from the RC panel. Setting the operating modes for each direction is independent, i.e. setting the operating mode for one direction does not change the operating mode set earlier for the opposite one.



Note. For the ACS outputs note the following:

High level — contacts of the output relay are broken or the output transistor is closed;

Low level — contacts of the output relay are closed or the output transistor is open

Table 3 Potential control mode (the jumper is taken off from the J1 connector)

№	The turnstile operating modes	Levels on the contacts should be provided	Indication on the RC panel	Indication on the led display	Turnstile status
1	Both directions are locked (the turnstile is locked both for entry and exit)	The high level — on contacts “Unlock A” and “Unlock B” or low level — on the contact Stop	The red indicator above the STOP button is on	The “Red cross” pictogram is on	The turnstile is locked
2	One of the passage directions is open (the turnstile is open for passage in the set direction)	The low level — on the contact corresponding to the passage direction, the high levels — on the other contacts	The green indicator above the button of the chosen passage direction is on	The “Green arrow” pictogram, showing the passage direction is on	If by the moment of passage through the turnstile the low level is present on the contact, corresponding to the set passage direction, the turnstile remains open in the set direction
3	Both passage directions are open (the turnstile is open for passage in both directions)	The low levels — are on the contacts corresponding to the both directions, the high level — on the contact Stop	The two green indicators (left and right) are on	The two “Green arrow” pictograms (left and right) are on	If by the moment of passage through the turnstile the low level is present on the contact, corresponding to the set passage direction, the turnstile remains open in the set direction

9.4 Actions in emergency

For urgent evacuation of people from business facilities in case of fire, natural calamities and other emergencies, the additional emergency exit should be provide.

To provide unobstructed and fast escape routes in emergency cases through the turnstile, the key override control is used. The sequence of actions is described in Clause 5.10 of the Manual.

Also the turnstile can be opened with a command sent from the *Fire Alarm* emergency unblocking device. The procedure is described in Clause 5.8 of the Manual.

9.5 Troubleshooting

Possible faults, which can be cleared by the users themselves, are listed in Table 4. All other faults shall be cleared by the Manufacturer or his representatives only.

Table 4. Possible faults and remedy

Fault	Possible cause	Remedy
At the power-up the turnstile won't work, and there is no light indication on the turnstile housing and the RC panel	No supply voltage to the CLB	Switch off the turnstile power supply from the AC mains, open the turnstile housing cover, and remove the outer panel. Check the power cable serviceability and reliability of its connection to the CLB XT3 connector block
The turnstile is not controlled in one of the directions, and there is light indication on the turnstile housing and on the RC panel	The CLB does not receive a control signal from this direction	Switch off the turnstile power supply from the AC mains, open the turnstile housing cover, and remove the outer panel. Check the RC panel / WRC kit / ACS controller cable serviceability and reliability of its connection to the CLB XT1.L and XT1.H connector blocks

10 MAINTENANCE

The turnstile housing maintenance is required once a year or in case of some technical failures. The maintenance should be carried out by qualified mechanic only. Prior to the turnstile maintenance works disconnect the turnstile power supply from the AC mains.



Caution!

Prior to the turnstile maintenance works disconnect the turnstile power supply from the AC mains.

The turnstile maintenance works should be carried out in the following order:

1. Remove the cover (2) with LED indication display from the turnstile housing. The order is given in Chapter 6.
2. Check visually the resetting device (pusher, springs and roller), the arm rotation sensors and the damper (Fig. 13).
3. Remove dust from the arm rotation sensor disc, located in the spacing of the arm rotation optical sensors, with alcohol-gasoline blend applied with a cloth. Avoid the ingress of dust on the operational spacing of the both arm rotation optical sensors.
4. Lubricate the friction units of the resetting device with the machine oil. Avoid the ingress of lubricant on the arm rotation sensor disc and the roller surfaces. Lubricate the following points (Fig. 13):
 - four bushes of the resetting device (two – on the rotation axis of the pusher, two – on the fastening axis of the springs);
 - holes in the fastening parts of the springs;
 - lock cylinder of the mechanical lock (15) through the keyhole.



Note!

Avoid the ingress of lubricant on the arm rotation sensor disc and the roller surfaces.

5. Check the reliability of the cable connections to the CLB connector blocks and if necessary tighten the cable fixing screws.
6. Connect the cable header of the indication board to the control mechanism connector and mount the cover with LED display (2) back into its place in the reverse order to the dismantling. When the cover (2) mounting is carried out correctly it does not need much effort.
7. Check the reliability of the barrier arm (5) fastening and, if necessary, tighten the bolts (6) of the barrier arms. To tighten the bolts:
 - remove the cover from the hub (3), of the turnstile housing, unscrewing the screw;
 - tighten the bolts (6) of the barrier arms (5) with the S13 socket wrench;
 - put the cover onto the hub (3), and fix it with the screw.
8. Check the reliability of the turnstile housing fastening to the floor and if necessary, tighten the anchor bolts (12) with S17 socket wrench:
 - remove plastic plugs (13) out of the holes in the turnstile housing base;
 - tighten the anchor bolts (12);
 - put the plastic plugs (13) into their places).

In case of any defects revealed during visual check please apply to the PERCo Technical Support Department (the PERCo TSD).

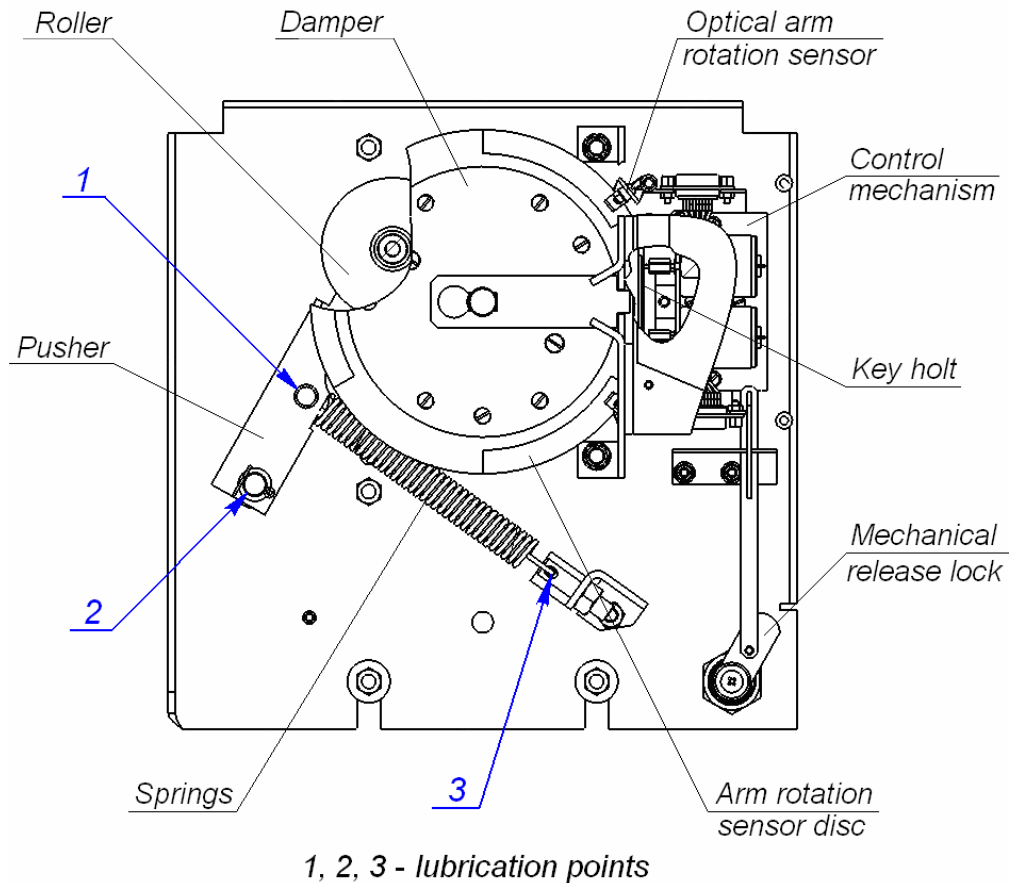

Figure 13. Location of the interior components of the turnstile housing (CLB is not shown)

11 TRANSPORTATION AND STORAGE

The turnstile in the original package should be transported in closed freight containers or in other closed type cargo transport units. During storage and transportation, the boxes can be stacked no more than 4 layers high.

The storage of the turnstile is allowed indoors at ambient temperature from -40°C to $+50^{\circ}\text{C}$ and at relative air humidity up to 75% at $+15^{\circ}\text{C}$. The environment should be free of acid and alkali vapours and gases that cause corrosion.

After transportation or storage at temperatures below zero or at high air humidity, prior to the installation the turnstile must be kept in the original package for no less than 24 hours indoors at room temperature.

Appendix A Control signal algorithm at pulse control mode

The following commands can be formed by sending a low-level signal to the contacts *Unlock A*, *Stop* and *Unlock B* of the *XT1.L* connector block relatively to the contact *GND* (The command is a signal active front (signal transfer from the high level to the low level) at any of the contacts at presence of the corresponding signal levels at the other contacts):

Always locked (closed for entry and exit) -

Active front is at contact *Stop* while there is a high level at contacts *Unlock A* and *Unlock B*.

Both passage directions get closed at this command.

Single passage in direction A (open for passage of one person in direction A) -

Active front is at contact *Unlock A* while there is a high level at contacts *Stop* and *Unlock B*.

At this command passage direction A opens either for 5 sec. or until the passage has been made in this direction or until the command “**Always locked**”, and the status of passage direction B does not change. The command is ignored if at the moment of its receipt the status of passage direction A was “**Always free**”.

Single passage in direction B (open for passage of one person in direction B) -

Active front is at contact *Unlock B* while there is a high level at contacts *Stop* and *Unlock A*.

At this command passage direction B opens either for 5 sec. or until the passage has been effected in this direction or until the command “**Always locked**”, and the status of passage direction A does not change. The command is ignored if at the moment of its receipt the status of passage direction B was “**Always free**”.

Single passage in both directions (open for single passage of one person at a time in each direction) -

Active front is at contact *Unlock A* while there is a low level at contact *Unlock B* and a high level at contact *Stop*,

or active front is at contact *Unlock B* while there is a low level at contact *Unlock A* and a high level at contact *Stop*.

At this command the both passage directions open either for 5 sec. each or until the command “**Always locked**” is received. The command is ignored for the passage direction, which status at the moment of its receipt was “**Always free**”.

Free passage in direction A (open for free passage in direction A) -

Active front is at contact *Unlock A* while there is a low level at contact *Stop* and a high level at contact *Unlock B*,

or active front is at contact *Stop* while there is a low level at contact *Unlock A* and a high level at contact *Unlock B*.

At this command passage direction A opens until the command “**Always locked**” is received and the status of passage direction B does not change.

Free passage in direction B (open for free passage in direction B) -

Active front is at contact *Unlock B* while there is a low level at contact *Stop* and a high level at contact *Unlock A*,

or active front at contact *Stop* while there is a low level at contact *Unlock B* and a high level at contact *Unlock A*.

At this command passage direction B opens until the command “**Always locked**” is received and the status of passage direction A does not change.

Free passage (open for passage in both directions) -

Active front is at contact *Unlock A* while there is a low level at contacts *Unlock B* and *Stop*, or active front is at contact *Unlock B* while there is a low level at contacts *Unlock A* and *Stop*,

or active front is at contact *Stop* while there is a low level at contacts *Unlock A* and *Unlock B*.

The both directions open at this command until the command “**Always locked**” is received.



Note! For the RC panel:

- active front — pressing of the relevant button on the RC panel;
- low level — the relevant button on the RC panel has been pressed;
- high level — the relevant button on the RC panel has not been pressed.

Appendix B Control signal algorithm at potential control mode

Both directions are closed (closed for entry and exit) -

There is a high level at contacts *Unlock A* and *Unlock B* or there is a low level at contact *Stop*.

The both passage directions close at this command.

Direction A is open (open for passage in direction A) -

There is a low level at contact *Unlock A* while a high level is present at contacts *Stop* and *Unlock B*.

At this command direction A opens up to the elimination of low-level signal from contact A or until the command “Both directions closed” is received, and the status of direction B does not change.

Direction B is open (open for passage in direction B) -

There is a low level at contact *Unlock B* while there is a high level at contacts *Stop* and *Unlock A*.

At this command direction B opens up to the elimination of low-level signal from contact B or until the command “Both directions closed” is received, and the status of direction A does not change.

Both directions are open (open for entry and exit) -

There is a low level at contacts *Unlock A* and *Unlock B* while there is a high level at contact *Stop*.

The both directions open at this command up to the elimination of low-level signal from one of the contacts A (B) or until the command “Both directions closed” is received.



Note! For an ACS controller outputs:

- low level — either contacts of the output relay are closed or the output transistor is open;
- high level — either contacts of the output relay are broken or the output transistor is closed.

PERCo

Polytechnicheskaya str., 4, block 2
194021, Saint Petersburg
Russia

Tel: +7 812 247 04 64

**E-mail: export@perco.com
support@perco.com**

www.perco.com



www.perco.com