



Motorized Electromechanical Swing Gate

WMD-06

ASSEMBLY AND OPERATION MANUAL



CE EAC



WMD-06
Motorized
electromechanical
swing gate

Assembly and Operation Manual

CONTENTS

1 APPLICATION.....	3
2 OPERATING CONDITIONS.....	3
3 TECHNICAL SPECIFICATIONS.....	3
4 DELIVERY SET.....	4
4.1 Standard delivery set.....	4
4.2 Optional equipment (upon request).....	5
5 DESCRIPTION.....	5
5.1 Main features.....	5
5.2 Design.....	5
5.3 RC-panel.....	8
5.4 Input and output signals parameters.....	9
5.5 Abnormal situations during gate operation.....	12
6 MARKING AND PACKAGING.....	12
7 SAFETY REQUIREMENTS.....	12
7.1 Installation safety.....	12
7.2 Operation safety.....	12
8 ASSEMBLY AND INSTALLATION.....	13
8.1 General recommendations.....	13
8.2 Tools and equipment required for installation.....	13
8.3 Appropriate cable length.....	13
8.4 Installation procedure.....	13
9 OPERATION.....	16
9.1 Power-up.....	16
9.2 Pulse control mode.....	17
9.3 Potential control mode.....	17
9.4 Emergency situations.....	18
9.5 Troubleshooting.....	18
10 TRANSPORTATION AND STORAGE.....	18
11 MAINTENANCE.....	18
APPENDIX A. Control signal algorithm in pulse control mode.....	19
APPENDIX B. Control signal algorithm in potential control mode.....	19

Dear customer!

*Thank you for purchasing the PERCo product.
Please follow instructions given in this Manual carefully,
and this quality product will provide many years of trouble-free use.*

The Assembly and Operation Manual (hereinafter – the Manual) contains the instructions the user will need for safe transportation, storage, installation, operation and maintenance of the **WMD-06** motorized electromechanical swing gate.

The product installation must be carried out by qualified installers in strict accordance with the Manual.

Abbreviations adopted in the Manual:

- ACS – access control system;
- RC – remote control;
- WRC – wireless remote control.

1 APPLICATION

The **WMD-06 motorized electromechanical swing gate** (hereinafter – the *swing gate*) is designed for managing pedestrian flows at entrance points of industrial facilities, banks, administrative buildings, retail outlets, railway terminals, airports, etc. Being an up-market model, it is recommended to meet the highest requirements for design and comfort. It can be installed together with other turnstiles and railings produced by **PERCo** or it can be used as a separate device.

It is recommended to define the number of swing gates necessary to secure fast and convenient passage in accordance with throughput rate (see Section 3). For example, it is recommended to install one turnstile per 500 people on the basis of maximum working load of 12 persons/min.

2 OPERATING CONDITIONS

The swing gate, with regard to resistance to environmental exposure, complies with GOST 15150-69, category U4 (operation in premises with climate control).

Operation of the swing gate is allowed at ambient air temperature from +1°C to +50°C and at relative air humidity of up to 70% at +27°C.

3 TECHNICAL SPECIFICATIONS

Operating voltage	24 V DC ±10%
Current consumption.....	max. 4.4 A
Power consumption	max. 105 W
Throughput rate in single passage mode.....	12 persons/min
Operating modes	3
Passageway width with AGG-650 swing panel	700 mm
Passageway width with AGG-900 swing panel	950 mm
Length of RC cable ¹	min. 6.6 m
IP Code	IP41 (EN 60529)
Electric shock protection class	III (IEC 61140)
Mean time to failure	min. 500 000 passages
Mean lifetime	min. 8 years
Overall dimensions with AGG-650 swing panel	795×147×1012 mm
Overall dimensions with AGG-900 swing panel	1045×147×1012 mm
Net weight with AGG-650 swing panel	max. 37 kg
Net weight with AGG-900 swing panel	max. 41 kg

¹ Maximum length of RC cable is 30 m (upon request).

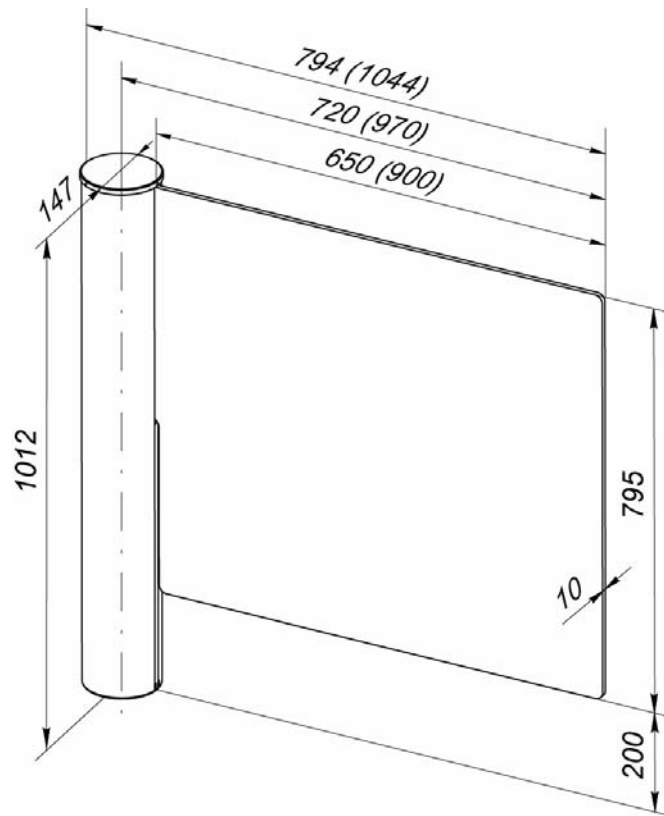

Figure 1. Overall dimensions

4 DELIVERY SET

4.1 Standard delivery set

Basic equipment:

Gate post:

fixed base 1

housing 1

cover 1

Glass panel 1



Note:

Type of panel, **AGG-650** (700 mm passageway width) or **AGG-900** (900 mm passageway width) is chosen by the customer.

RC panel with cable 1

SW1.5 Allen wrench 1

Gate mounting kit:

PFG IH 10 (SORMAT, Finland) anchor bolt with washer and M10 nut 3

Panel installation kit:

M10×35 bolt 4

M10 nut 4

Spring washer 4

Expanded washer 8

Plastic bushing 4

Operational documentation:

Certificate 1

Assembly and operation manual 1

Template for gate installation 1

Package:

Box 1 (gate post and RC-panel) 1

Box 2 (swing panel) 1

4.2 Optional equipment (upon request)

In addition to the standard delivery set the following equipment can be supplied on request:

Power supply unit	1
WRC kit ¹	1

5 DESCRIPTION

5.1 Main features

- The swing gate can operate both as a standalone unit and as a part of the ACS. Two control modes are available: pulse control mode and potential control mode.
- The swing gate can be supplied with two types of swing panel: 650 mm or 900 mm. Overall dimensions of the gate are shown in Fig. 1.
- External components of the swing gate (except for swing panel) are made of polished stainless steel. The swing panel is made of 10 mm thick tempered glass.
- The swing gate is a normally open unit i.e. in case of power failure the swing panel can rotate $\pm 90^\circ$.
- Safe operating voltage – max. 28 V.
- Low power consumption – max. 105 W.

5.2 Design

Design of the swing gate is shown in Fig. 2. The numbers of the items in brackets are given according to Fig. 2, unless stated otherwise.

The gate consists of the fixed base (1), rotary support (7) that holds glass panel (4), housing (2) and cover (3). The metal (5) and plastic rings (12) provide support of housing (2) and its rotation around fixed base (1). Decorative plate (15) is fixed with a screw (16).

The gate post is installed on anchors stud-bolts (9) and fixed with nuts (10) and washers (11)

The gate post contains units providing its operation: rotary electric drive with rotation sensor, electromagnetic stopper unit, bearing units, drive control board (6).

RC panel is included into delivery set (17).

The gate is operated with +24 V DC voltages via cable (13).

The control board is installed inside the gate post. The control board overview is shown in Fig. 3. The control board contains:

- **XT1** and **XT2** – terminal blocks are designed for power supply, input-output of control signals and indication. Marking and description of **XT1** and **XT2** terminal block contacts of the control board are given in Table 1.
- **Size** – connector is designed for selection of swing panel type installed on the gate. If the **AGG-900** panel is used, the jumper shall be removed, if the **AGG-650** panel is used – the jumper shall be installed. The jumper is removed by default.
- **Imp / Pot** – connector is designed for selecting gate control mode. If the jumper is installed, the gate operates in the pulse mode, if the jumper is not installed, the gate operates in the potential mode. The jumper is installed by default.
- **FireAlarmDir** – connector is designed for selecting gate opening direction when the *Fire Alarm* emergency unlocking signal is applied. If the jumper is installed, the swing panel opens in direction A (see Figure 5), if the jumper is not installed, the swing panel opens in direction B. The jumper is installed by default.
- **LED** – connector is designed for turn-off of LED indicators located on the control board. If the jumper is installed, indication is on. If the jumper is not installed, indication is off. The jumper is installed by default.

¹ WRC kit consists of a receiver connected to the gate control board and two transmitters (tags) with operating range up to 40 m.

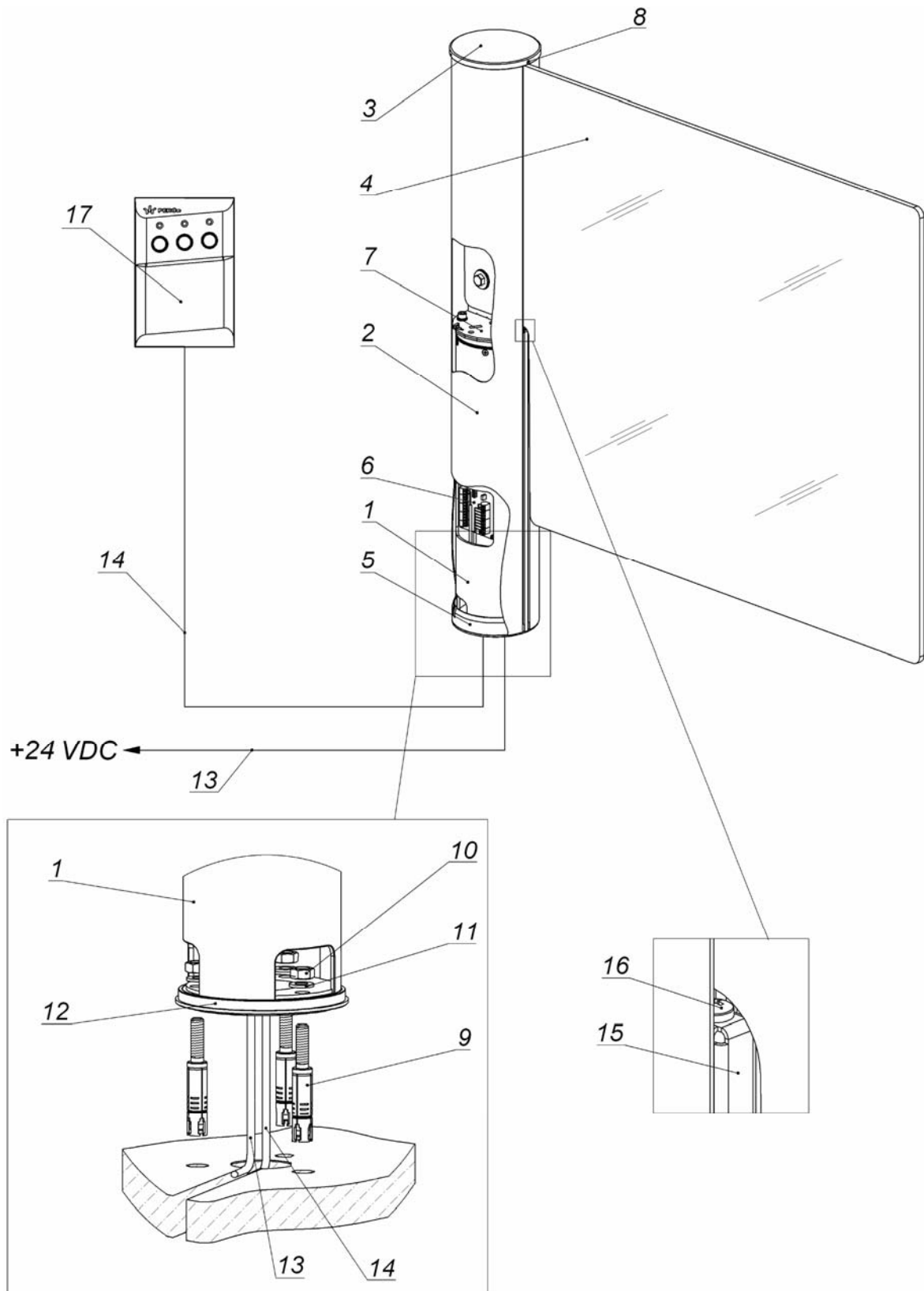

Figure 2. Overall view of the gate

- 1 – fixed base; 2 – housing; 3 – cover; 4 – glass panel; 5 – metal ring;
- 6 – control board; 7 – rotary support; 8 – M3 screw (3 pcs); 9 – anchor stud-bolt; 10 – M10 nut;
- 11 – washer; 12 – plastic ring; 13 – power cable;
- 14 – control cable (from RC panel / WRC device / ACS controller);
- 15 – decorative plate; 16 – screw M4; 17 – RC panel

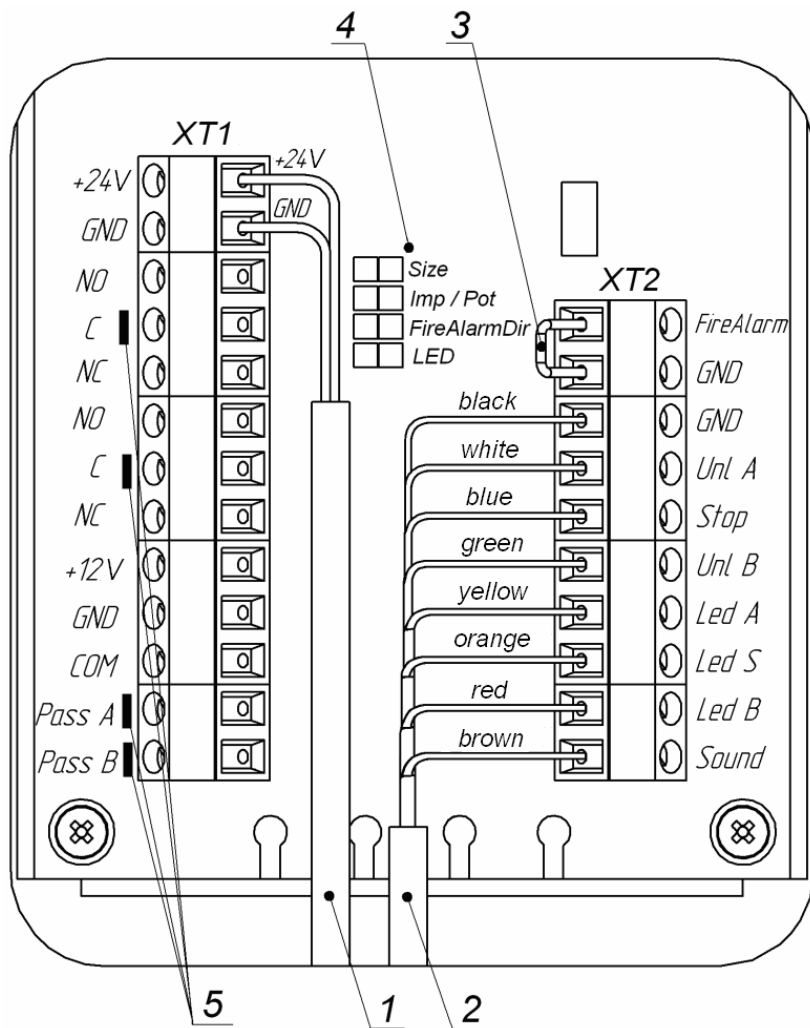

Figure 3. Control board overview

- XT1, XT2** – terminal blocks; 1 – power cable +24 V;
 2 – control cable (from RC panel / WRC unit / ACS controller);
 3 –jumper wire (installed by default);
 4 – connectors (all jumpers are installed by default); 5 – LED indicators.

Table 1. Contacts of the control board

Terminal block	No.	Item	Designation
XT1	1	+24 V	External power supply connection
	2	GND	
	3	NO	Light A relay contacts – remote indicator connection for direction A
	4	C	
	5	NC	
	6	NO	Light B relay contacts – remote indicator connection for direction B
	7	C	
	8	NC	
	9	+12 V	Power supply positive terminal of RC-panel
	10	GND	Power supply negative terminal
	11	Common	Common contact for PASS A, PASS B signals
	12	Pass A	PASS A relay contact (passage in direction A)
	13	Pass B	PASS B relay contact (passage in direction B)

Terminal block	No.	Item	Designation
XT2	1	Fire Alarm	Input for emergency unlocking device
	2	GND	
	3	GND	Power supply negative terminal
	4	Unlock A	Inputs for gate control
	5	Stop	
	6	Unlock B	
	7	Led A	Indication outputs of RC panel
	8	Stop	
	9	Led B	
	10	Sound	Sound signal output of RC panel

5.3 RC-panel

The RC-panel (17) is a small desktop device made of shockproof ABS plastic that serves for manual setting of the operating modes and indication thereof. RC-panel is connected to the control board (6) with flexible multicore cable (14), included into delivery set. The RC-panel overview is shown in Figure 4.

The RC panel features three control buttons to set swing gate passage modes. The buttons LED indicators are located above. The **STOP** button in the middle serves for setting the “**Always locked**” operating mode, the **RIGHT** and **LEFT** buttons – for allowing passage in the chosen direction. The RC panel features a built-in piezoelectric buzzer for audio signals generation.

The standard orientation of the RC panel in relation to gate opening direction is shown in Figure 5. The orientation of the RC panel buttons can be changed if necessary, in such case the connection of RC panel shown in Fig. 11 shall be changed by swapping the cable of the RC panel to **XT2** terminal block in accordance with Table 2.

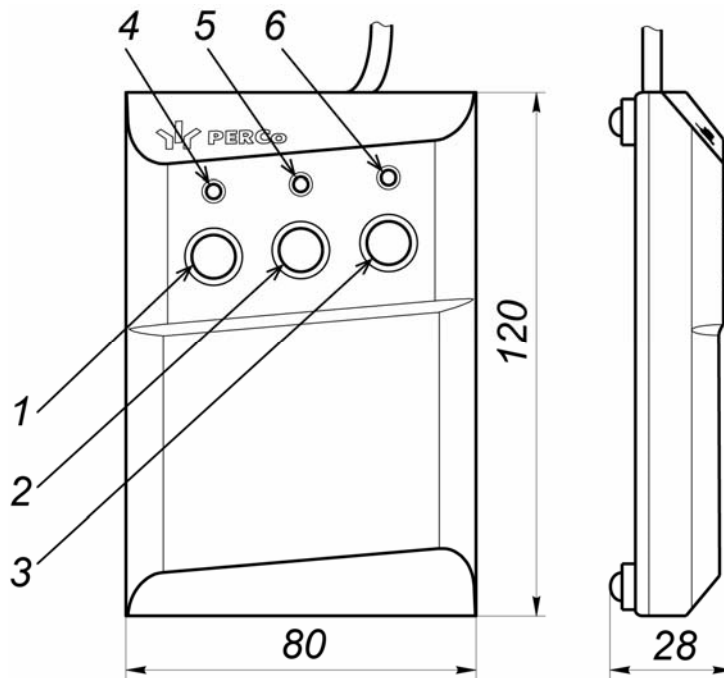

Figure 4. RC panel overview and dimensions

1, 2, 3 – **LEFT, RIGHT, STOP** buttons for mode setting;
 4, 6 – “**Left**” and “**Right**” green indicators; 6 – “**Stop**” red indicator

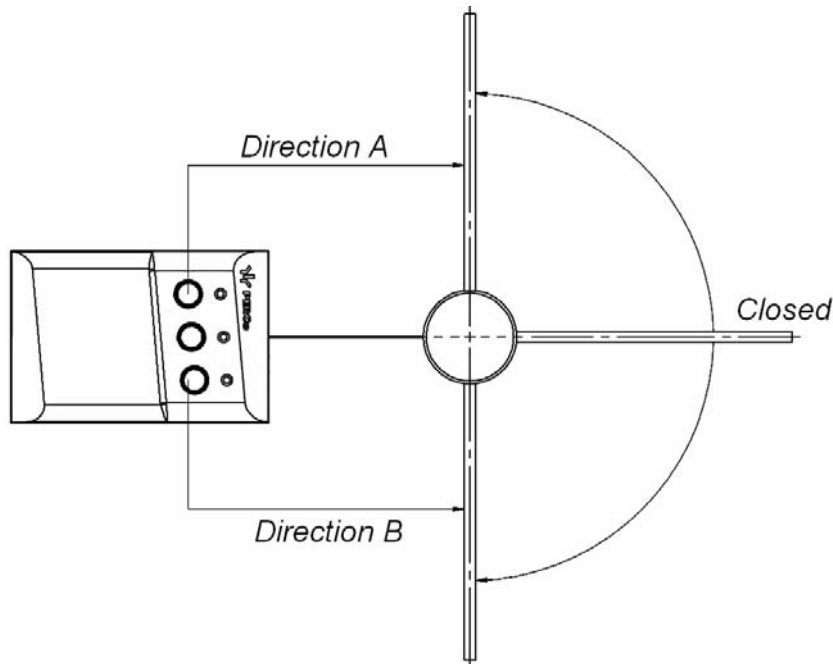

Figure 5. Standard orientation of RC panel relative to gate opening direction

Table 2. Connection of RC panel cable to XT2 connector block in standard and reversed orientation of the RC panel

Number	Title	Orientation	
		Standard	Reversed
1	Fire Alarm	-	-
2	GND	-	-
3	GND	black	black
4	Unlock A	white	green
5	Stop	blue	blue
6	Unlock B	green	white
7	Led A	yellow	red
8	Stop	orange	orange
9	Led B	red	yellow
10	Sound	brown	brown

5.4 Input and output signals parameters

The microcontroller installed on the control board tracks the status of *Unlock A*, *Stop*, *Unlock B* and *Fire Alarm* control input signals, and also tracks output signals from rotation sensor.

Upon received data the microcontroller generates commands for the gate control mechanism and also signals for connected external indication devices, indication on the RC panel (*Led A*, *Led Stop* and *Led B*), signals on the performed rotation of the swing panel on outputs *Pass A* and *Pass B*.

5.4.1 Inputs for control devices connection

The swing gate can be operated with RC panel, WRC device or ACS controller.

A device that sends *Fire Alarm* signal is used for passage emergency unlocking.



Note:

Control devices (RC panel, WRC device, ACS controller) can be connected separately or in any combination with each other.

In case of combined connection, the overlapping of signals sent by control devices may occur. In such case the reaction of the gate will correspond with the reaction towards the generated combination of input signals.

Control devices are connected to *Unlock A*, *Stop* and *Unlock B* control inputs. The gate is operated by applying a low-level signal to *Unlock A*, *Stop*, *Unlock B* contacts with *GND* contact of **XT2** terminal block. Algorithms of control signals sending are given in Appendices A and B.

A normally open relay contact or open collector output circuit can be used as a control element (see Figure 6 and Figure 7).

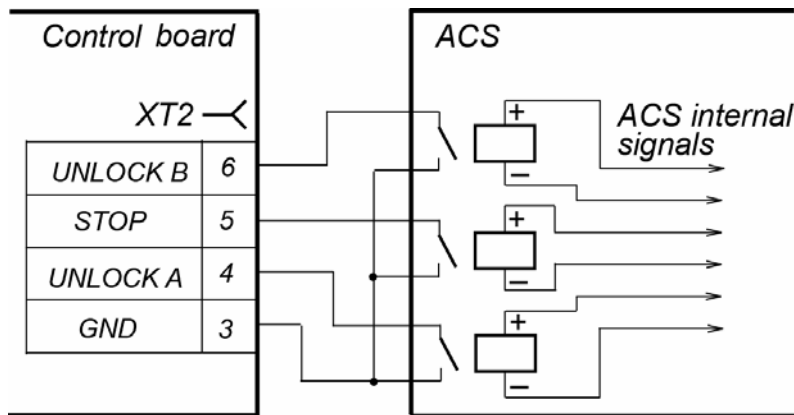

Figure 6. ACS control element – normally open relay contact

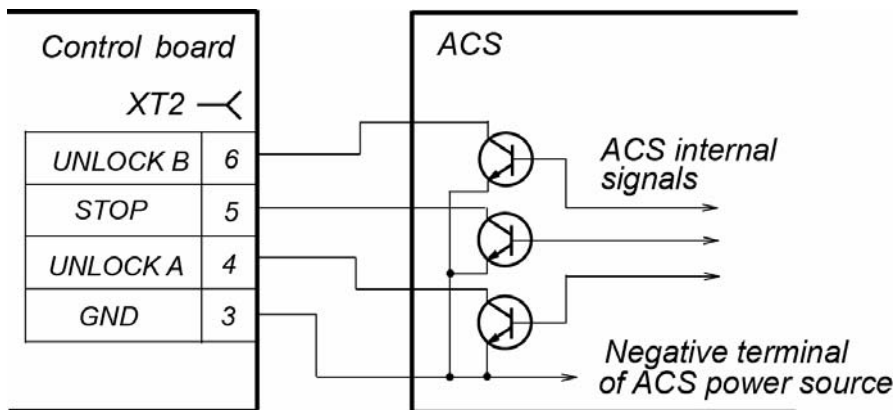

Figure 7. ACS control element – open collector output circuit

The device that sends *Fire Alarm* emergency unlocking signal is connected to the *Fire Alarm* control input. Emergency unlocking is performed by turn-off of the low-level signal at *Fire Alarm* contact and *GND* contact on **XT2** terminal block. In such case a normally closed contact or open collector output circuit can be used as a control element.

If the *Fire Alarm* input is not used, it is necessary to install a jumper between *Fire Alarm* and *GND* contacts on the **XT2** terminal block. The jumper is installed by default.

The gate can operate in two control modes: pulse and potential. Control mode is set by installing or removing the jumper on **Imp / Pot** connector. If the jumper is installed, the gate operates in the pulse control mode; if the jumper is removed, the gate operates in the potential control mode. The jumper is installed by default. Algorithms of control signals sending for each control mode are given in Appendix.

Connection of devices to control inputs is performed in accordance with wiring diagram, shown in Fig. 11.



Note:

To generate high-level signal on all input contacts (*Unlock A*, *Stop*, *Unlock B*, *Fire Alarm*) 2 kOhm resistors connected to + 5 V power line are used.

Control element shall meet the following signal requirements:

control element – relay contact:

- minimum switching current max. 2 mA
- closed contact resistance
- (including connection cable resistance) max. 300 Ohm

control element – open collector output circuit:
 voltage at the closed contact
 (low-level signal, at the control board input) max. 0.8 V

5.4.2 PASS outputs

PASS A (Pass A and Common contacts of **XT1** terminal block), PASS B (Pass B and Common contacts of **XT1** terminal block) outputs are basically a relay.

If the power is turned off, control board relays are normally open. In such case *Common* contact is not connected to the negative terminal of the gate's power supply (see Fig. 8).

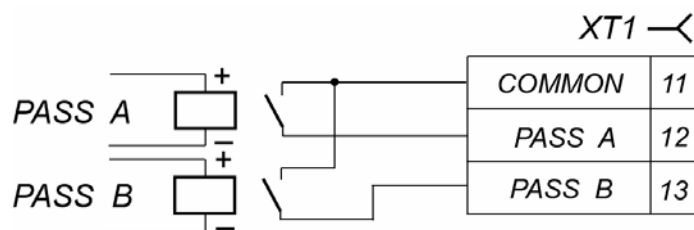

Figure 8. Output stages for PASS A, PASS B

If the status is normalized and the power is turned on, relay coil is energized and *PASS A*, *PASS B* relay contacts are closed.

PASS A, *PASS B* relays activation/deactivation can be defined by activation/deactivation of indicators that are installed near the related outputs on the control board (see Fig. 3).

Output stages for *PASS A*, *PASS B* relay contacts have the following signal specifications:
 maximum switching voltage 42 V DC
 maximum switching current 0.25 A
 closed contact resistance max. 0.15 Ohm

5.4.3 Outputs for external indication connection

Light A and *Light B* outputs are used for external indication connection and are basically relay changeover contacts (see Fig. 9). Each output has full contact set on **XT1** terminal block: normally open (*NO*), normally closed (*NC*) and common (*C*). Connection is performed in accordance with the wiring diagram given in Fig. 11.

Light A (*Light B*) relay is activated (meaning that its coil is energized) when the passage is open in the direction A (B) and normalized when the passage is closed in the related direction.

Light A (*Light B*) relays activation/deactivation can be defined by activation/deactivation of indicators that are installed by the near related outputs on the control board.

Output stages for *Light A* (*Light B*) are relay changeover contacts with the following signal specifications:

maximum switching DC voltage 30 V
 maximum switching AC voltage 42 V
 maximum switching AC / DC 3 A
 closed contact resistance max. 0.15 Ohm

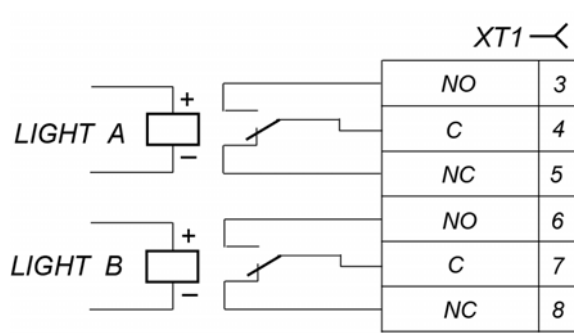

Figure 9. Output stages for Light A and Light B

5.5 Abnormal situations during gate operation

In a case of any impediment to the free rotation of the swing gate an automatic switching to overload mode is provided. The mode is used to avoid damage to electromechanical elements due to overheating.

If any obstacle impedes rotation of the swing panel, three attempts of rotation in the same direction are made with 3 sec intervals. If the obstacle remains, the swing gate switches to overload mode. Being in the overload mode the swing panel can rotate free $\pm 90^\circ$ that allows removing the obstacle. In such case all three indicators on the RC panel are blinking, and a sound indication consisting of three short audio signals is turned on each 20 sec.

The overload mode is switched off by rotating the swing panel into the “Closed” position manually or by turning the power supply off and then on (in this case the gate will be set into home position automatically).

6 MARKING AND PACKAGING

The swing gate has a marking label located inside the rotary post under the cover. The label contains the trademark and contact details of the manufacturer, the manufacture date, voltage and power consumption. To access to the marking take off the post cover by unscrewing three 3 screws using SW1.5 Allen wrench.

The swing gate in the standard package is packed in two boxes that protect it from being damaged during transportation and storage. The box 1 contains gate post and RC panel, the box 2 contains a swing panel. Boxes have the marking of the packed product and additional marking in accordance with design documents and delivery set.

Dimensions, (L×W×H):

box 1	121×37×22 cm
box 2 for AGG-650 glass panel	96×12×90 cm
box 2 for AGG-900 glass panel	121×12×90 cm

Gross weight:

box 1	max. 36 kg
box 2 for AGG-650 swing panel	max. 28 kg
box 2 for AGG-900 swing panel	max. 35 kg

7 SAFETY REQUIREMENTS

7.1 Installation safety

Installation should be performed by qualified personnel only, in strict accordance with the Manual and general electrical safety requirements for electrical and installation work.



Attention!

- All the connections should be performed only after the control unit is disconnected from the power supply.
- Only serviceable tools should be used.
- Cables should be laid in accordance with electrical safety requirements.
- Before first activation of the gate, check whether the installation and all connections are performed correctly.

The installation of power supply unit shall be performed in accordance with general safety requirements given in its operation manual.

7.2 Operation safety

Observe general safety requirements for use of electrical equipment.



Warning!

- Do not use the swing gate in environment different from those given in Section 2.
- Do not use the swing gate with power supply unit different from those given in Section 3.

Power supply unit shall be operated in accordance with general safety requirements given in its operation manual.

8 ASSEMBLY AND INSTALLATION

Observe safety requirements given in the Section 7.1 during installation.

8.1 General recommendations

Proper installation is crucial to performance and serviceability of the swing gate. We advise you to study this Manual before installation work and follow the instructions to the latter.

We recommend:

- to mount the swing gate on a steady concrete foundation (grade 400 or higher), stone or similar foundations of at least 150 mm thick.
- to make sure the mounting foundation is horizontal and steady, so that all the mount points lie in the same plane;
- to employ reinforcing elements 450×450×200 mm, when installing on a less steady foundation.

8.2 Tools and equipment required for installation

Use the following tools for the installation works:

- 1.2÷1.5kW hammer drill;
- Ø16 mm hard-alloy drill bits for anchor bolts sleeves;
- Phillips head screwdriver No.1;
- SW1.5 Allen wrench;
- S17 open-end wrench;
- hobby knife;
- level;
- measuring tape 2 m.



Note:

The use of different tools is acceptable on condition that they do not reduce the quality of installation works.

8.3 Appropriate cable length

Maximum acceptable length of RC panel / ACS controller cable 30 m

Maximum acceptable length of power supply cable depends on its cross-section and shall be as following:

for 1.5 mm² cross-section (AWG 15)max. 10 m
for 2.5 mm² cross-section (AWG 13)max. 20 m

8.4 Installation procedure



Attention!

The manufacturer shall not be liable for any damage caused in the result of improper installation and declines any claims arising thereof in case if the installation is not in compliance with the instructions provided in this Manual.

Item numbers in the installation sequence are given accordingly to Fig. 2, unless stated otherwise. Wiring diagram is given in Fig. 11. Terminal blocks and jumpers positioning on the control board is given in Fig. 3. Cables used for installation and their maximum lengths are set in Section 8.3. Recommendations on surface preparation are given in Section 8.1. Follow this sequence during gate installation:

1. Unpack the box with equipment, check carefully the delivery set according to Section 4.



Attention!

Don't hold the gate by its cover (3) while moving it.

2. Mark and prepare the mounting holes in the floor as per Fig. 10 for anchors (9) to install the gate post (If necessary, use the supplied template). Use Ø16 mm hard-alloy drill for hole preparation. Drilling depth is 60 mm.

3. Install power supply unit in accordance with its operation manual.

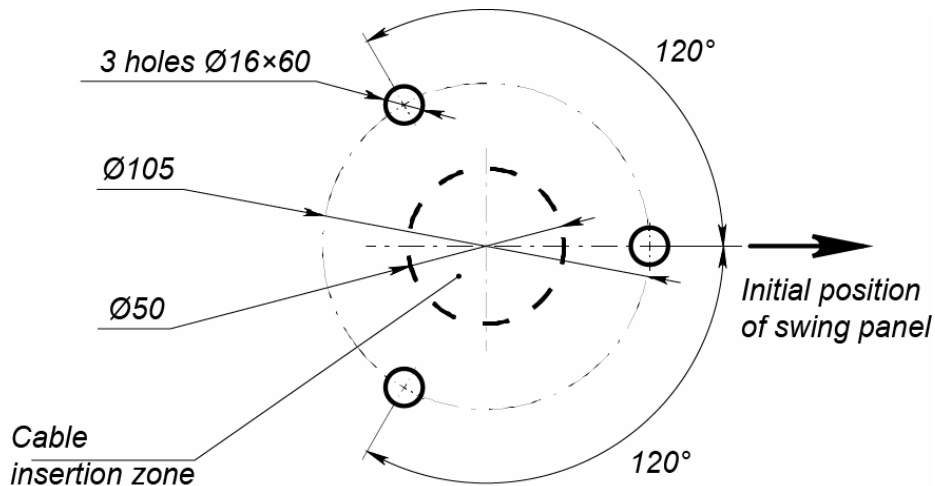

Figure 10. Mounting hole layout

4. If it is necessary to lay power cables (13) and control cables (14) under the floor, prepare an electrical conduit in the floor in the zone where cables are inserted into the gate post. The zone positioning is given in Fig. 10.
5. Install anchors in the drilled holes in the floor, so that their sleeves would not obtrude out of the floor surface.
6. Lay power cable and route the cable inside electrical conduit towards cable insertion zone. Pull cables inside the fixed base (1) to the length appropriate for following installation on the control board (6).



Attention!

Install and fix the gate post only when all cables are laid inside electrical conduit and the gate post. Be careful until the post is not fixed, prevent it from falling down.

7. Install the gate post on anchors (9). Put it vertically by using a lever. Mounting pads may be used. Vertical deviation shall not exceed 0.5° in two planes.
8. Remove the metal ring (5). Put a washer (11) on each anchor and fix the gate post with three M10 nuts (10).
9. Connect power cable and control cable to **XT1** and **XT2** terminal blocks of the control board (6). Put cables as shown in Fig. 3.
10. If needed, connect *Fire Alarm* emergency unlocking device. If the device is not connected, a wire jumper shall be installed on *Fire Alarm* and *GND* contacts on **XT2** terminal block.
11. If it is necessary, connect external indicators to **XT1.2** and **XT1.3** terminal blocks.
12. If it is necessary, change the position of jumpers on the control board.
13. Mount the glass panel according to Fig. 12. Fix the panel (6) on the rotary support (7) with elements (1) – (5).



Attention!

Be careful while mounting the glass panel, prevent it from falling and hitting by metal elements of the post. Due to the significant weight of the panel, it is recommended to put a support under it during the assembly.

14. Install the metal ring (5). Put the gate housing (2) on the post moving it alongside the post axis till it stops.
15. Install the cover (3) on the top having unscrewed the bolts (8) using SW 1.5 Allen wrench. Fix the cover with the bolts.

When the installation is finished turn the gate on and test its operation in accordance with Section 9.1.

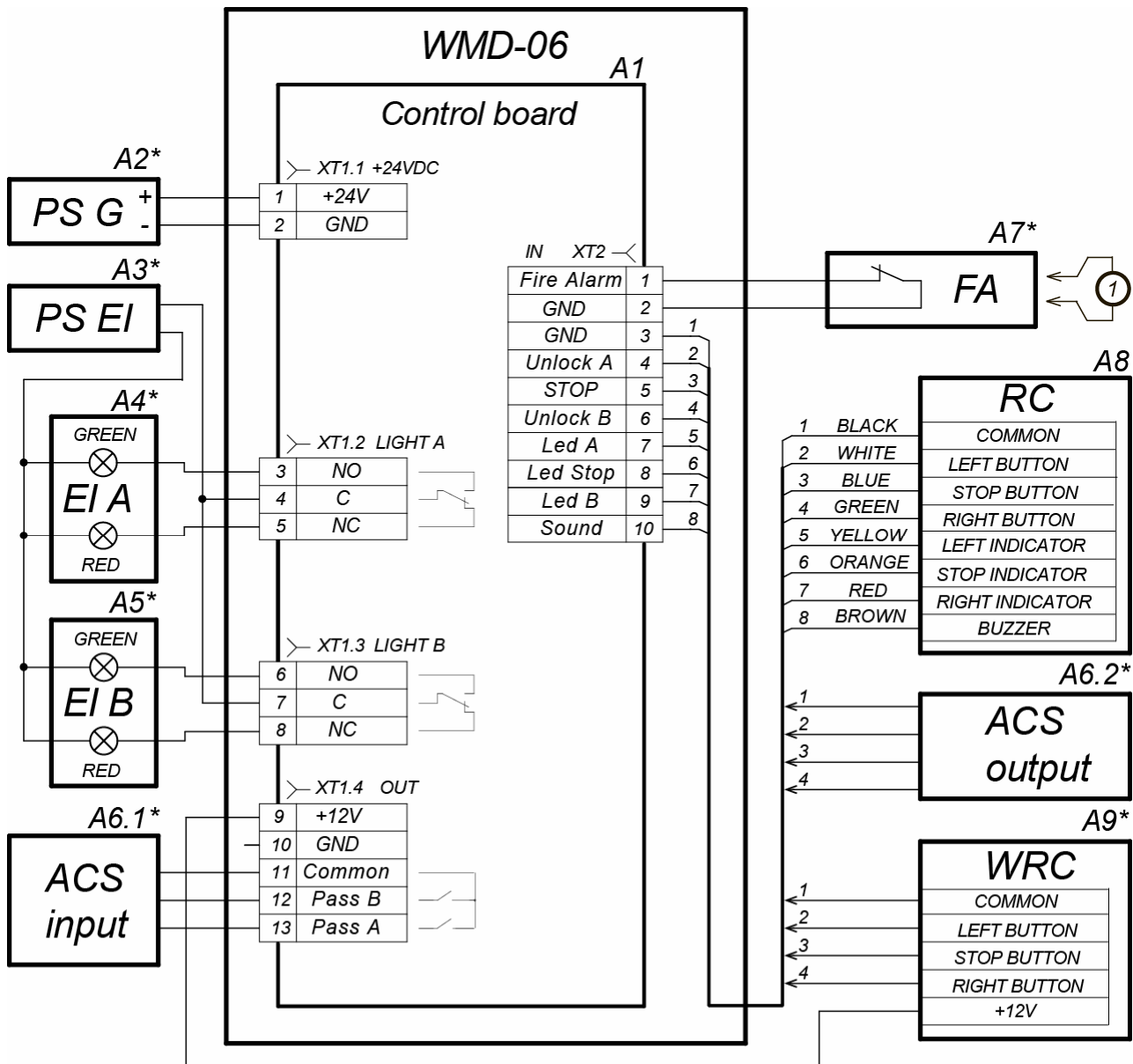

Figure 11. Wiring diagram

Table 3. List of elements on the wiring diagram

Item	Designation	Comment
A1	Control board	
A2*	Power supply unit of the swing gate	+24V DC; 4A
A3*	Power supply unit of remote indicators	
A4*, A5*	Remote indicators	2 pcs
A6.1*	ACS controller input	
A6.2*	ACS controller output	
A7*	Device sending <i>Fire Alarm (FA)</i> emergency unlocking signal	
A8	RC panel	PERCo-H6/4
A9*	WRC device	
1	Wire jumper. Installed when the <i>Fire Alarm</i> device (A7) is not connected.	Installed on default

* Not included in standard delivery set.

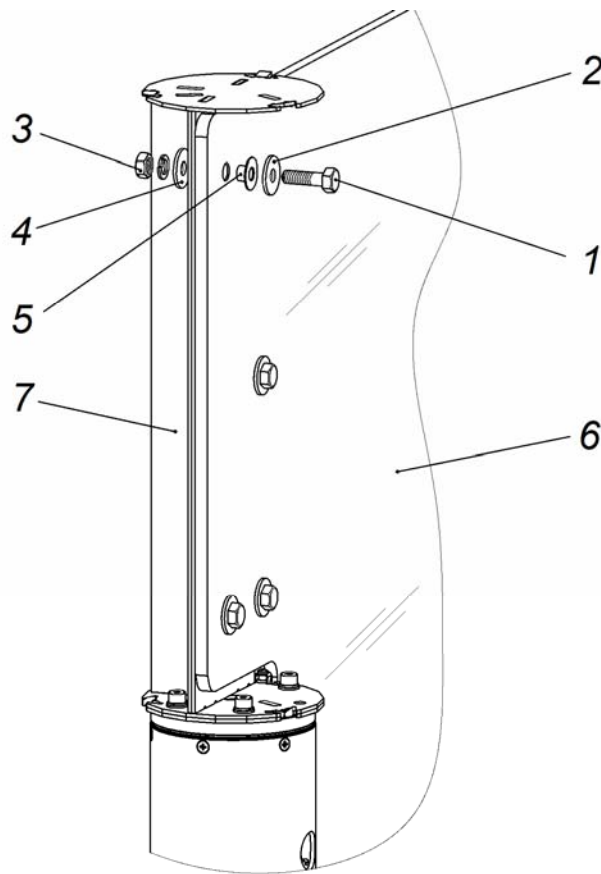

Figure 12. Glass panel mounting

1 – M10 bolt; 2 – plastic bushing; 3 – M10 nut; 4 – spring washer; 5 – expanded washer; 6 – glass panel; 7 – rotary support

9 OPERATION

Observe safety requirements given in Section 7.2.



Warning!

- Do not move any objects through the passageway whose dimensions exceed the width of the passageway.
- Do not hit elements of the swing gate so as to prevent their mechanical damage.
- Do not dismantle or adjust mechanisms ensuring operation of the swing gate.
- Do not use substances for cleaning of the swing gate that may cause mechanical damage or corrosion of the surfaces.

9.1 Power-up



Attention!

Make sure that there are no obstacles in the rotation zone and passageway of the gate before starting the power-up.

Perform the following actions in order:

1. Connect the power cable to the electric socket with voltage and frequency set in the certificate of the power supply unit.
2. Turn the power supply unit on.
3. The swing gate will detect “Closed” position in automatic mode (see Figure 5).
4. In the pulse control mode the swing gate will switch to the “Always locked” mode, in the potential mode the swing gate will switch to the “Locked in both directions” mode. The red indicator located above the **STOP** button on the RC panel will turn on.

The swing gate is ready for operation.

9.2 Pulse control mode

Pulse control mode is used to operate the swing gate with RC panel, WRC devices and ACS controllers that support this mode.

Operating modes setting is performed by applying a low-level signal or by closing *Unlock A*, *Stop*, *Unlock B* contacts with *GND* contact of **XT2** terminal block. In such case the duration of the control signal shall be at least 100 ms. Algorithm of control signals is given in Appendix A. Indication of the RC panel and the swing panel position are given in Table 4.

Table 4. Operating modes in pulse control mode (“Imp/Pot” jumper is installed)

Operating mode	Operator’s actions on RC-panel	RC-panel indication	Panel position
“Always locked”	Press the STOP button.	Red indicator above the STOP button	Panel is the in “Closed” position and is locked
“Single passage in chosen direction”	Press the LEFT or RIGHT button corresponding to the chosen passage direction.	Green indicator above the button responsible for the chosen passage direction, red indicator above the STOP button	Panel opens in chosen direction for a single passage
“Free passage”	Press the STOP button and the button corresponding to the chosen passage direction simultaneously	Green indicator above one of the buttons responsible for the passage direction	Panel opens in one of the directions and remains in this position until the mode is changed.

The gate remains open for 4 sec. in the “Single passage in chosen direction” mode. Timing starts after the swing panel rotates 85°. After that the swing panel moves to “Closed” position and locks, the swing gate switches to the “Always locked” mode.

“Single passage in chosen direction” mode can be changed to “Free passage” mode in the same direction or to “Always locked” mode; “Always free” mode can be changed to “Always locked” mode only.

9.3 Potential control mode

Potential control mode is used to operate the swing gate with ACS controllers that support this mode.

Operating modes setting is performed by holding a low-level signal at *Unlock A*, *Stop* and *Unlock B* contacts and *GND* contact on the **XT2** terminal block. Algorithm of control signals is given in Appendix B. Indication of the RC panel and the swing panel position are given in Table 5.

Table 5. Operating modes in potential control mode (“Imp/Pot” jumper is removed)

Operating mode	Provided signal	Operator’s actions on RC panel	RC panel indication	Panel position
“Both directions closed”	Low-level – on <i>Stop</i> contact, high-level – on <i>Unlock A</i> and <i>Unlock B</i> contacts.	Press and hold the STOP button	Red indicator above the STOP button	Panel switches to the “Closed” position
“Direction open”	Low-level – on <i>Unlock A</i> or <i>Unlock B</i> contact (corresponding to the chosen passage direction), high-level – on other contacts <i>Stop</i> , <i>Unlock B</i> (<i>Stop</i> , <i>Unlock A</i>).	Press and hold the LEFT or RIGHT button, corresponding to the chosen passage direction	Green indicator above the button responsible for the chosen passage direction	Panel opens in chosen direction and remains so until the low-level signal on the corresponding contact is turned off

The duration of waiting period for “*Direction open*” mode is defined by the duration of control signal on the contact related to opening direction of the swing panel.

9.4 Emergency situations

In case of fire, disasters and any other emergency situations it is necessary to provide emergency exit to evacuate people. For example, **BH-02** anti-panic rotary sections can be used as an emergency exit.

The passageway of the swing gate can be used as an additional emergency exit. The construction of the gate allows providing exit without use of any special keys or tools. Apply *Fire Alarm* control signal to the control board. The swing panel will open automatically making the passage free regardless of the set operating mode. Other control commands will be ignored. The opening direction is defined by **FireAlarmDir** jumper on the control board. When the signal is turned off, the swing panel moves to “*Closed*” position and locks.

Device sending *Fire Alarm* emergency unlocking signal is not included into standard delivery set.

Besides, the swing gate is basically a normally open device, meaning that in case of power failure the swing panel can rotate manually $\pm 90^\circ$, making the passage free.

9.5 Troubleshooting

Possible faults to be corrected by the user themselves are listed in Table 6. In an unlikely event of other faults please consult the **PERCo** Technical Support Department.

Table 6. Troubleshooting

Fault	Possible cause	Remedy
When powered-up, RC-panel indication does not work	No supply voltage on control board	De-energize power supply unit. Remove the cover and housing of the gate. Check the power cable and its connection to the XT1 terminal block.
The gate cannot operate in one of the directions, RC-panel indication is on	Control signal of chosen direction is not applied to the control board	De-energize power supply unit. Remove the cover and housing of the gate. Check the cable of RC panel / WRC device / ACS controller and its connection to the XT2 terminal block

10 TRANSPORTATION AND STORAGE

The swing gate in the original package should be transported only in closed freight containers or other closed type cargo transport units.

During storage and transportation boxes with swing gate posts can be stacked no more than 2 layers high. Stacking of boxes with glass panels is not allowed.

The swing gate should be stored in dry indoor facilities at ambient temperatures from -40°C to $+50^\circ\text{C}$ and at relative air humidity of up to 98% at $+25^\circ\text{C}$.

After transportation or storage at below-zero temperatures or high air humidity, the swing gate should be kept unpacked for minimum 24 hours under normal climate conditions corresponding to operation conditions.

11 MAINTENANCE

Technical maintenance of the swing gate should be performed only at **PERCo** service center.

We recommend using liquid non-abrasive cleansers containing ammonia to clean a swing gate post and a glass panel when dirty.

APPENDIX A. Control signal algorithm in pulse control mode

The command is a signal active front (signal transfer from the high level to the low level) at any of the contacts at presence of the corresponding signal levels at the other contacts.



Note:

RC panel:

- active front – pressing of the relevant button,
- low level – the relevant button has been pressed,
- high level – the relevant button has not been pressed.

The following commands can be formed by sending a low-level signal to *Unlock A*, *Stop* and *Unlock B* contacts and *GND* contact on the **XT2** terminal block relative to the *GND* contact:

Always locked (locked for entry and exit) - active front is at the contact *Stop* while there is a high level at the contacts *Unlock A* and *Unlock B*. Both passage directions are locked at this command.

Single passage in the direction A (open for passage of one person in the direction A) - active front is at the contact *Unlock A* while there is a high level at the contacts *Stop* and *Unlock B*. At this command the passage direction A opens either for 5 sec. or until the passage has been made in this direction or until the “*Always locked*” command, and the status of the passage direction B does not change at that. The command is ignored if at the moment of its receipt the status of the passage direction A is “*Always free*”.

Single passage in the direction B (open for passage of one person in the direction B) - active front is at the contact *Unlock B* while there is a high level at the contacts *Stop* and *Unlock A*. At this command the passage direction B opens either for 5 sec. or until the passage has been effected in this direction or until the command “*Always locked*”, and the status of the passage direction A does not change. The command is ignored if at the moment of its receipt the status of passage direction B is “*Always free*”.

Free passage in the direction A (open for free passage in the direction A) - active front is at the contact *Unlock A* while there is a low level at the contact *Stop* and a high level at the contact *Unlock B*, or active front is at the contact *Stop* while there is a low level at the contact *Unlock A* and a high level at the contact *Unlock B*. At this command the passage direction A opens until the command “*Always locked*” is received; the status of the passage direction B does not change at that.

Free passage in the direction B (open for free passage in the direction B) - active front is at the contact *Unlock B* while there is a low level at the contact *Stop* and a high level at the contact *Unlock A*, or active front is at the contact *Stop* while there is a low level at the contact *Unlock B* and a high level at contact *Unlock A*. At this command the passage direction B opens until the “*Always locked*” command is received; the status of the passage direction A does not change at that.

APPENDIX B. Control signal algorithm in potential control mode



Note:

For ACS controller outputs:

- high level – either contacts of the output relay are broken or the output transistor is closed,
- low level – either contacts of the output relay are closed or the output transistor is open.

Both directions are locked (locked for entry and exit) - there is a high level at the contacts *Unlock A* and *Unlock B*, or a low level at the contact *Stop*. The both passage directions are locked at this command.

The direction A is open (open for passage in the direction A) - there is a low level at the contact *Unlock A* while a high level is present at the contacts *Stop* and *Unlock B*. At this command the direction A is opened till the low-level signal removal from the contact *Unlock A* or until the command “*Both directions locked*” is received. The status of the direction B does not change at that.

The direction B is open (open for passage in the direction B) - there is a low level at the contact *Unlock B* while there is a high level at the contacts *Stop* and *Unlock A*. At this command the direction B is opened till the low-level signal removal from the contact *Unlock B* or until the command “*Both directions locked*” is received. The status of the direction A does not change at that.

PERCo

Polytechnicheskaya str., 4, block 2
194021, Saint Petersburg
Russia

Tel: +7 812 247 04 64

**E-mail: export@perco.com
support@perco.com**

www.perco.com



www.perco.com